



MV Airo 2 Boost & Airo 4

ALPINE AUTO

INSTRUCTION MANUAL

Ed 1.02

MV Heating UK Ltd
Unit 6
Second Avenue Business Park
Millbrook
Southampton
SO15 0LP



2.2kW and 4kW Air Heaters

MV Heating UK LTD
+44 (0)2380 522345



Preface

Thank you for purchasing the MV Airo 2 Boost and/or Airo 4 diesel powered hot air heater. This instruction book describes the structures, working principles, installation, and operation of the MV Airo 2/5. For correct use of the heater, please read this instruction book carefully before installation and use. The instruction book should be saved in a convenient place for reference later.

Note

- This instruction book is subject to revision without notice, but the instruction book is in conformity to the purchased product.
- Our effort is to explain all questions you may have. If you have any doubts or find anything incorrect in this manual, please contact us directly.
- Check the heater for any damage when unpacking and contact the dealer immediately if anything is found.
- If any troubles arise during application, please contact MV Heating or other customer service stations authorized by this company. We shall do our best to provide service to you.

Comply with the operation manual for installation and operation, to ensure prolonged and reliable use.



Contents

Uses and Applications	4
Safety Information	5
Technical Data	6
MV Airo 2 Boost Technical Data	6
MV Airo 2 Boost Current Draw	6
MV Airo 4 Technical Data	7
MV Airo 4 Current Draw	7
Internal Structure	8
Installation Parts	9
Installation of the Main Heater Body	12
MV Airo 2 Boost Dimensions	12
MV Airo 4 Dimensions	13
Installation Positions	14
Wiring Harness Connector Positions	16
Mounting Gasket and Plate Dimensions	17
Angle of Installation	18
Installation: Mounting	19
Air Inlet & Outlet	20
Ducting Configuration	21
Exhaust System	22
Combustion Air Intake	23



Installation: Fuel Lines	24
Fuel Line Connectors.....	25
Fuel Line Length and Order.....	26
Fuel Pump Angle for Installation.....	27
Fuel Tank Head.....	28
Fuel Standpipe	29
Electrics: Components	31
Airo 2 Boost & 4 Main Connector	31
Control Unit Connector.....	32
Accessory Plug Connector.....	32
Auxiliary Unused Connection.....	33
Temperature Sensor Probe Connector	33
Installing Temperature Probe	34
ECU Connections.....	35
Wiring Diagram	36
Maintenance	37
Fault Codes.....	38
Notes	39



Uses and Applications

The heater works independently from the vehicle's engine but is best fitted using the vehicle's battery and fuel tank. An auxiliary battery and/or fuel tank can be used if necessary.

The heater will operate under normal conditions in most vehicles from industrial and machinery sectors to leisure craft like yachts and motor homes.

The heater is best uses for heating various cabins and compartments, engine preheating and glass defrosting.

It is **not recommended** for constant long-term operation for residential rooms, garages, holiday homes etc.

Note:

The most common faults that occur are generally down to poor fuel conditions due to dirty (or empty) fuel tanks or drops in voltage; particularly in older vehicles like live aboard narrowboats or used, commercial vehicles.



Safety Information

Follow the installation guidelines carefully to ensure the heater has the appropriate amount of clearance between surfaces, so as not to become a fire hazard and that the various parts of the heater that get hot, like the exhaust, are not exposed or contaminated by possible fuel and oil.

Sufficient ventilation is required allowing proper airflow to the heater. If the heater is to be installed in a box or compartment, please ensure an air (breather) vent is installed for this reason. The air must also be fresh and not contaminated by exhaust fumes or other polluted sources. Make sure that the air intakes and exhaust do not get blocked by other objects.

Take care to ensure that the exhaust outlet is installed in a way that prevents fumes entering the vehicle or in the direction of the fresh air intake and ensure the use of heat shields where necessary to again avoid fire damage.

If work is to be carried out on or around the heater, turn it off at least an hour before so, so that it is sufficiently cool enough to be handled. If necessary, wear safety gloves.

The fuel line must not be routed through the passenger compartment or the driver's cab in any vehicle. Ensure that they are also installed so that the exits are not at risk or in danger of becoming a possible fire hazard.

Finally, take care and follow any and all precautions when installing the heater to minimize injuries to yourself and damage to the heater.



Technical Data

MV Airo 2 Boost Technical Data

Heat Power (W)	2200
Fuel	Diesel
Output (W)	850 (Min) - 2200 (Max)
Fuel Consumption (l/h)	0.1 - 0.28
Run Time Power Consumption (w)	7 - 20
Weight (kg)	2.7
Working Temperature	-40°C - 20°C

MV Airo 2 Boost Current Draw

Variable Output	Current Draw
Position	(Amps)
PO1	0.4
PO2	0.5
PO3	0.8
PO4	1.1
PO5	1.5
PO6	2.0
PO7	2.4



MV Airo 4 Technical Data

Heat Power (W)	4000
Fuel	Diesel
Output (W)	900 - 4000
Fuel Consumption (l/h)	0.11 - 0.51
Run Time Power Consumption (w)	8 - 40
Working Temperature	-40°C - 20°C
Weight (kg)	4.5

MV Airo 4 Current Draw

Variable Output	Current Draw
Position	(Amps)
P01	0.4
P02	0.6
P03	0.9
P04	1.4
P05	2.0
P06	3.0
P07	4.3

Internal Structure

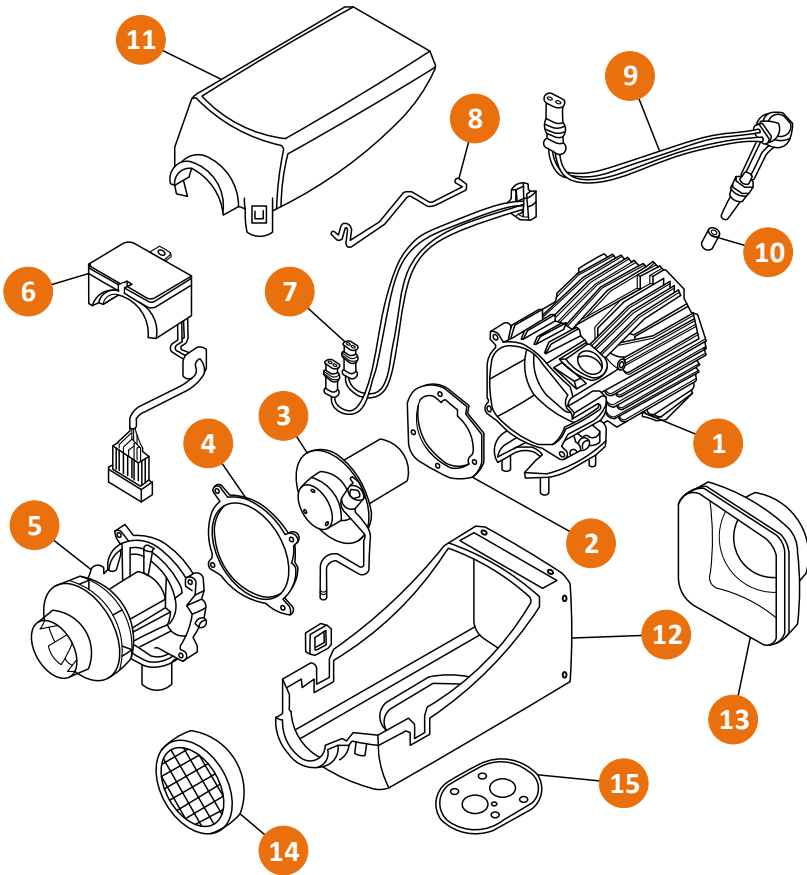

Figure 1

- | | | |
|----------------------------|-------------------------|----------------------------|
| 1. Heat exchanger | 2. Burner Gasket | 3. Burner Assembly |
| 4. Air Motor Gasket | 5. Air Motor | 6. ECU |
| 7. Overheat Sensor | 8. Spring Clip | 9. Glow Pin |
| 10. Glow Pin Screen | 11. Top Case | 12. Bottom Case |
| 13. Outlet Cover | 14. Inlet Grill | 15. Mounting Gasket |

Installation Parts

Parts included for a standard installation.

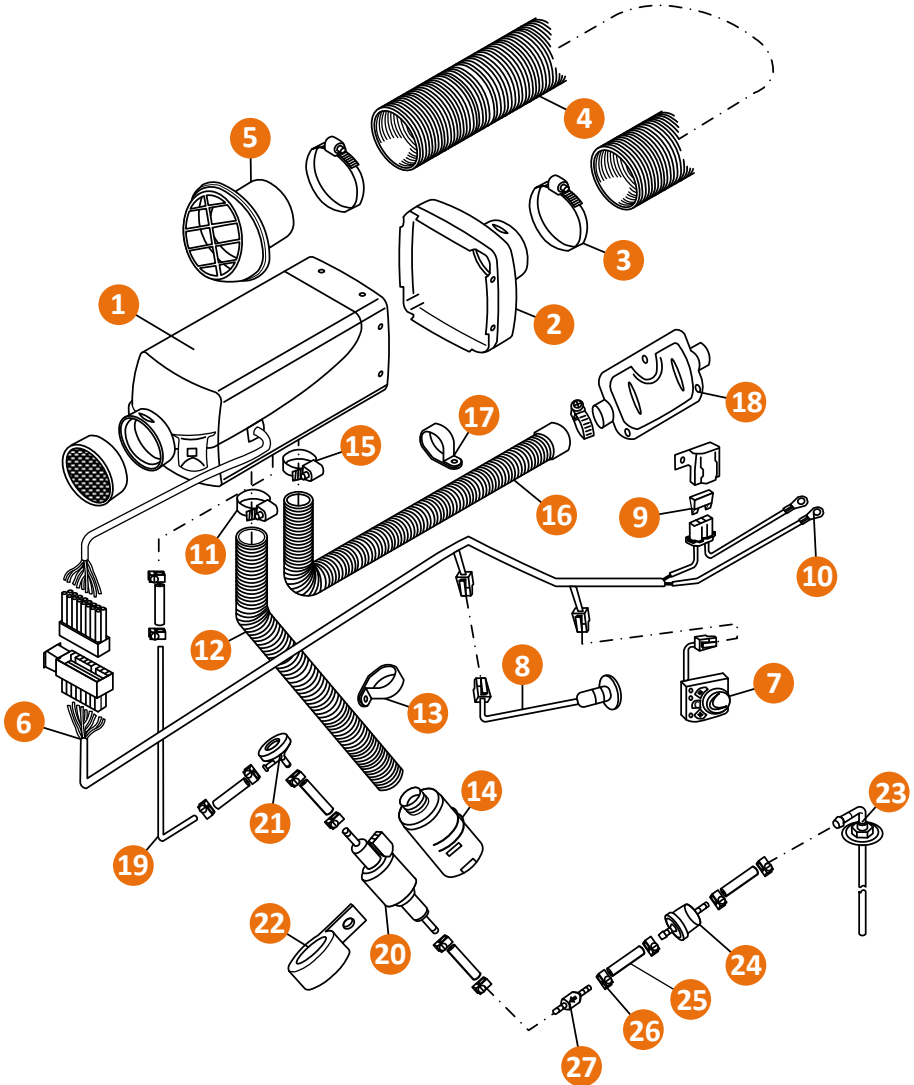

Figure 2



1. Main heater unit
2. Outlet Case
3. Hose Clip
4. Hot Air Ducting
5. Hot air Outlet Vent
6. Main Wiring Harness
7. Control Unit
8. Temperature Sensor Probe**
9. Main Fuse (12V = 20A, 24V = 15A)
10. To Power Supply
11. Combustion Air Clamp
12. Combustion Air Pipe
13. Combustion Air 'Strap'
14. Combustion Air Silencer/Filter
15. Exhaust Pipe Clamp
16. Exhaust Pipe
17. Exhaust Pipe P-Clip
18. Exhaust Silencer*
19. Fuel Pipe
20. Fuel Pump
21. Fuel Pump Damper
22. Fuel Pump Mount
23. Fuel Standpipe
24. Fuel Filter
25. Fuel Pipe Connector
26. Fuel Pipe Connector Clamp
27. Fuel non-return valve (optional)

*Unsealed in a vehicle application and must be installed outside of the vehicle. When purchased as part of a marine kit, the silencer will be sealed and attached to the exhaust pipe as part of a single system.

**Not necessary with OLED control systems

Figure 2 shows the diagram for an Airo installation. The position and ways of fixing of various parts may vary from one vehicle/boat to another, but the general principles remain the same.

Attention:

- Do not mount the heater near any flammable sources.
- Do not install the heater in closed spaces without ventilation.
- Do not place the heater near anything that can cause a blockage.
- Do not mount the heater near any water sources and protect it from any splashing or road debris.

+44 (0)23 8052 2345



Installation of the Main Heater Body

For the ease of servicing, fault finding and air flow it's recommended that the main body is placed in an area with easy access. Figure 3 shows the minimum distances required on the MV Airo 2 Boost and Figure 4 shows the distances for the larger Airo 4 model.

MV Airo 2 Boost Dimensions

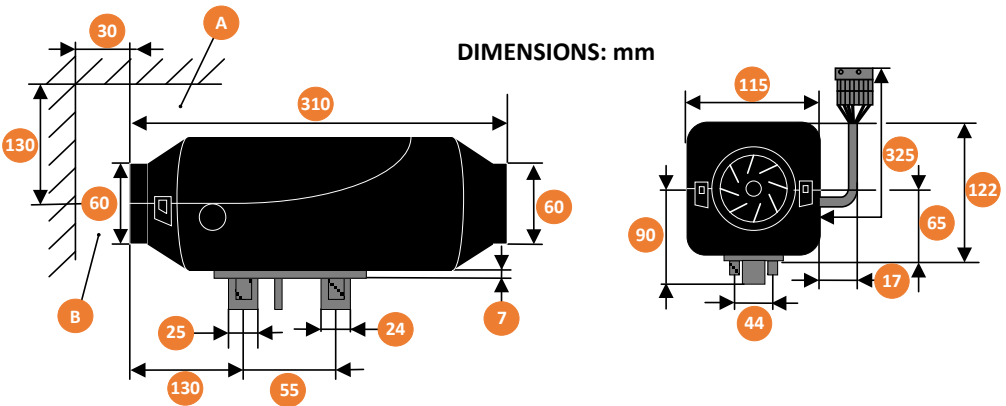

Figure 3

A: Minimum installation clearance for opening the lid and dismantling glow pin and E.C.U.

B: Minimum installation clearance for the air intake

MV Airo 4 Dimensions

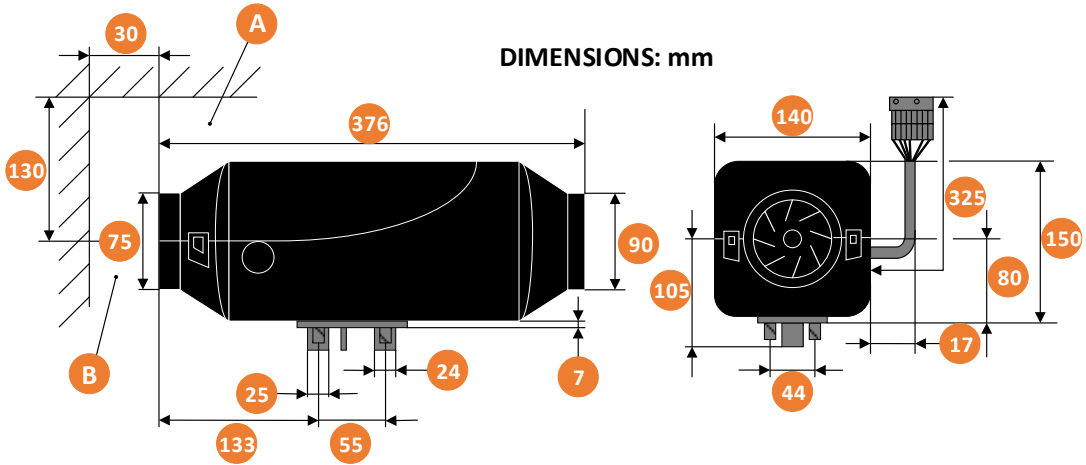

Figure 3

A: Minimum installation clearance for opening the lid and dismantling glow pin and E.C.U.

B: Minimum installation clearance for the air intake

Choose a flat installation surface, any undulations could cause the case to twist and will not ensure an even mount. Make sure there are no foreign bodies between the bottom of the heater and the installation surface itself. This will ensure a good seal between the two. File down any drill holes to again ensure an even mounting surface. Use the mounting gasket and plate provided, particularly if the mounting surface is less than 1.5mm thick. Tighten the M6 nuts provided to a torque setting of 6Nm+1Nm.

Installation Positions

Motorhome

Figure 4

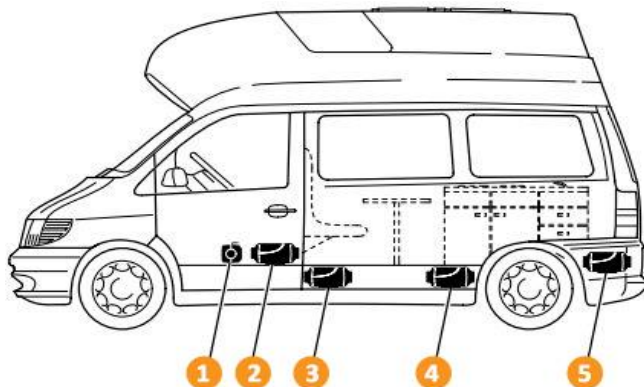

1. In front of the passenger seat
2. Between the passenger and driver's seat
3. Under the vehicle floor
4. Under the rear seat
5. Inside the boot

Minivan

Figure 5

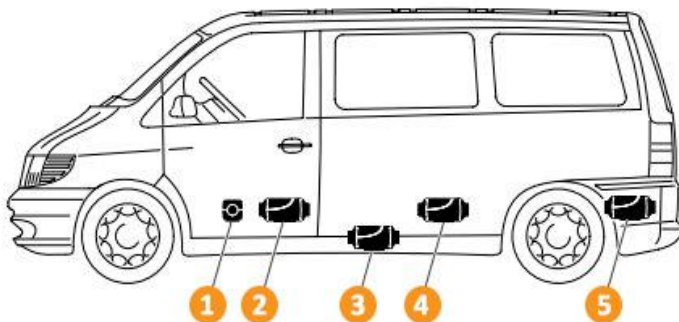

1. In front of the passenger seat
2. Between the passenger and driver's seat
3. Under the vehicle floor
4. Under the rear seat
5. Inside the boot

Industrial

Figure 6

- 1. In seat box
- 2. On the rear wall
- 3. In a protective case



Lorry

Figure 7

- 1. In passenger footwell
- 2. On the cabin rear wall
- 3. Under the bed
- 4. In the toolbox

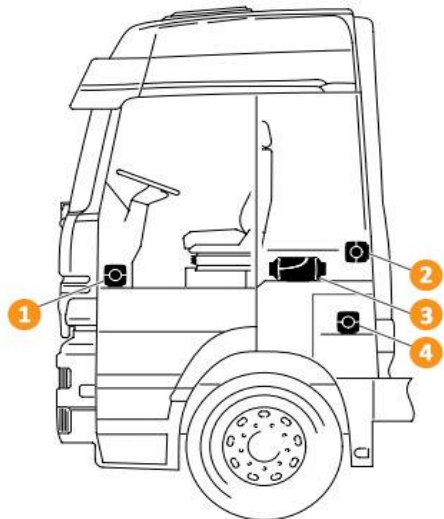

Wiring Harness Connector Positions

The main connector coming off the heater can be moved to the other side of the heater if necessary. To do so you must first remove the air inlet grill by twisting it so it's clear of its securing lip and then simply pull it off. Next, remove the top cover by lifting the two front flaps near the air inlet. You can then lift out the entire innards of the heater (heat exchanger to fan motor and all) removing the cable from the rubber securing bush and rerouting it underneath the fan motor where it can then sit in the cut-out on the opposite side. Ensure the rubber bush is properly inserted, and the heat exchanger is back securely in position. Then simply replace the lid and grill back in position.

Note: Ensure the bottom cover fits correctly inside the groove of the lid.

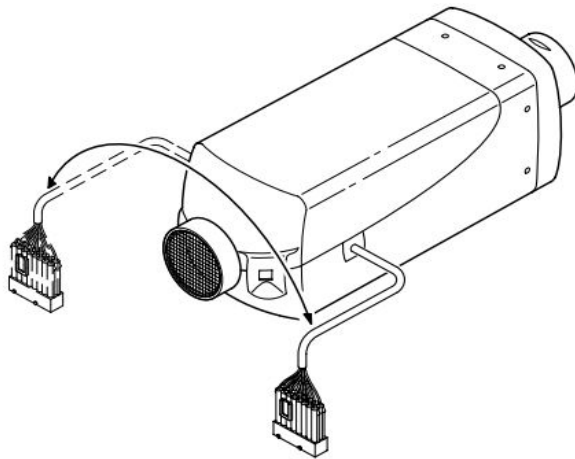

Figure 8

Mounting Gasket and Plate Dimensions

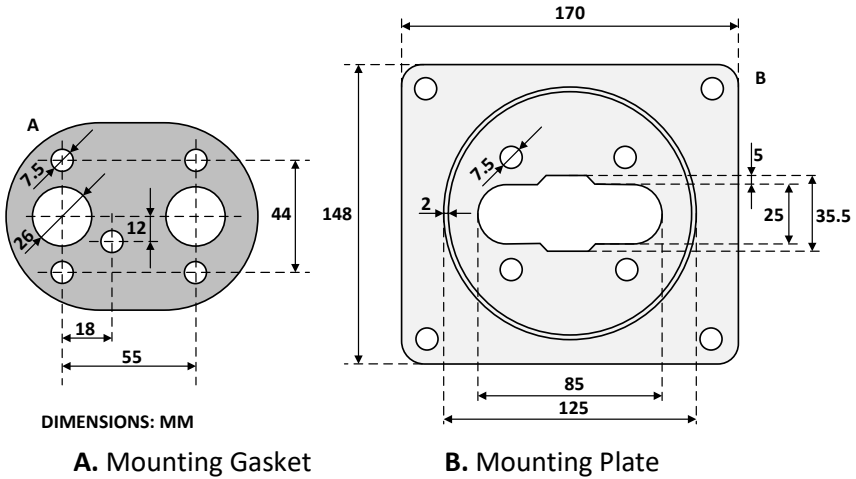

Figure 9

The mounting gasket and mounting plate required in most vehicle installations is shown above. Marine and other applications may require a bulkhead ('L' shaped) mounting bracket. The heater's main footprint remains the same.

If the heater is being reinstalled, a new mounting gasket should be used.

Angle of Installation

All positions suggested are examples. Other locations are possible so long as they correspond to the proper installation guidelines and requirements.

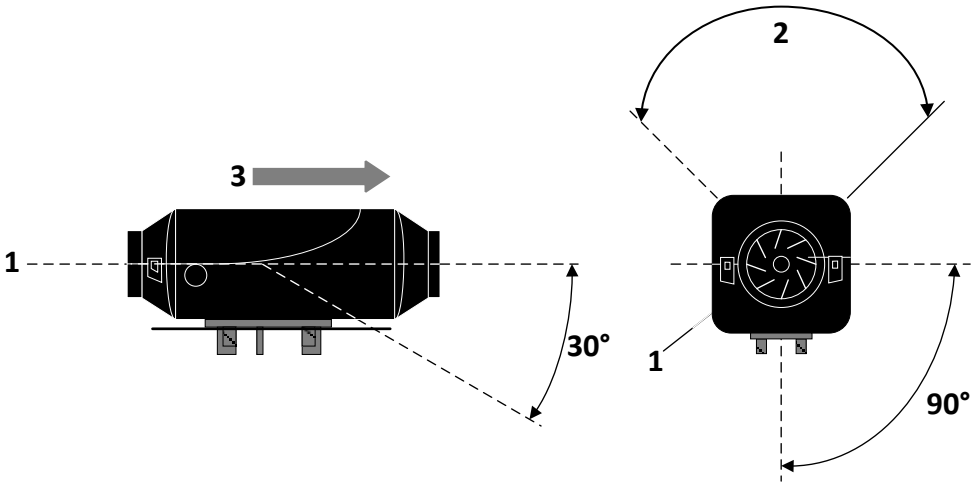

1. Heater air intake 2. Glow pin position 3. Direction of air flow

Figure 10

Figure 10 shows the ideal installation position of the heater; with exhaust pointing downward. Depending on its location it can be tilted by 30° with the air flow and hot air outlet facing the bottom. It can also be tilted on its longitudinal axis by 90° so long as the glow pin position points upward. During usual operation the heater can deviate by 15° each way with vehicle movement without impaired function of the heater.

Air Inlet & Outlet

Ducting Size Airo 2 Boost– 60mm

Ducting Size Airo 4 – 90mm

Make sure that the hot air outlet does not exit onto any parts affected by heat and that it isn't directed toward the flow of anything that can cause a blockage, near splashing water or near the vehicles exhaust.

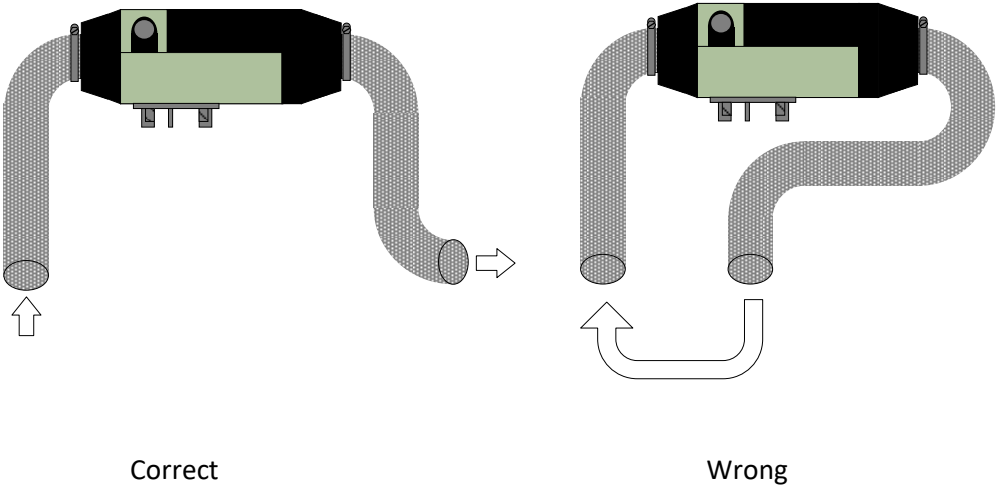

Figure 12

Avoid re-entering of the supplied hot air into the inlet port (as shown in Figure 12). If no inlet pipe is required, make sure the grill is installed at the inlet port (Figure 1 no. 14) to prevent blockages.

Ducting can be configured in various ways as shown overleaf. Larger ducting sizes like the Airo 5 can be reduced in some applications but care must be taken not to cause overheating if reduced considerably.

Ducting Configuration

Using the MV Airo 2 Boost as an example:

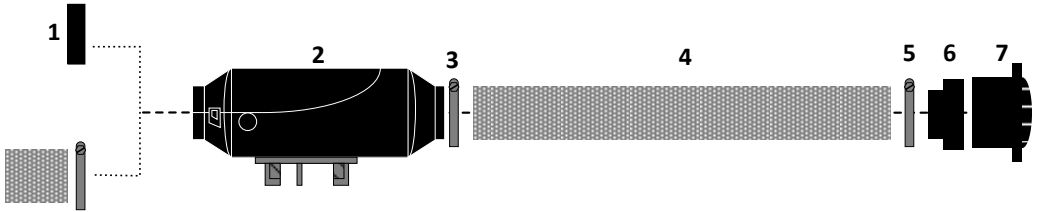

Figure 13

1. Ducting AND/OR Grill
2. Main Heater body
3. 60mm Hose Clip
5. 60mm Hose Clip
7. 80mm Directional Vent

2. Main Heater body
4. 60mm APK Ducting
6. 60mm Reducer

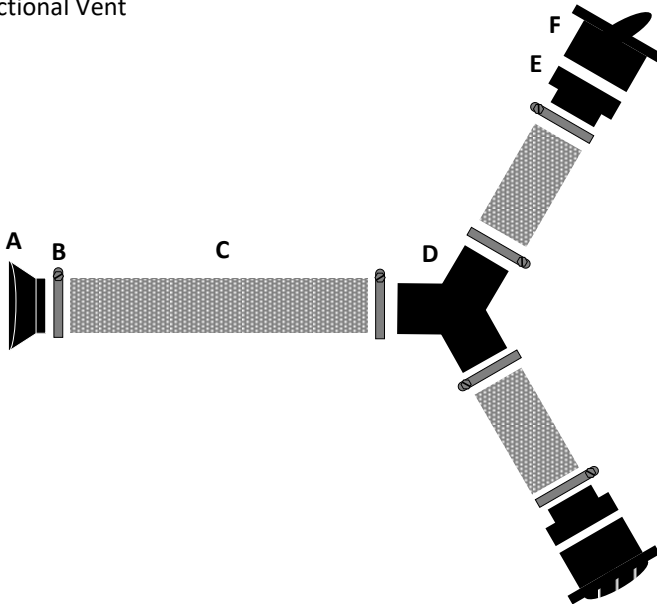

Figure 14

- A. Heater's hot air outlet
- C. 60mm APK ducting
- E. 60mm Reducer

- B. 60mm hose clip
- D. 60mm 'Y' branch
- F. 80mm outlet vent

Exhaust System

Note: Do not work on the exhaust system unless the heater has been switched off for over an hour and wear safety gloves if necessary. All types of combustion produce high temperatures and toxic fumes and must be installed in accordance with these instructions.

The flexible exhaust pipe can be shortened to no less than 20cm and should not exceed a length of 2.3m, depending on the installation parameters. Route the exhaust pipe from the heater to a suitable outlet, ensuring that it is securely fitted to the heater using the clamp supplied in the kit.

As the exhaust gets very hot during operation, it should be installed in such a way that will not cause damage to the vehicle. Ensure that it has sufficient clearance of heat sensitive parts, paying close attention to fuel lines (plastic and copper) and electrical components.

Make sure that the outlet ends in open air and does not point in the direction of travel. The whole system should also point downwards with an angle of $90^{\circ} \pm 10^{\circ}$. This is best achieved by fixing a clamp 150mm from the pipe end. If necessary, a 5mm hole should be drilled near the bottom to drain off any condensation. You should also route the exhaust so that the fumes are not taken back in by the air intake of the heater and ensure that the outlet does not get blocked by anything like road debris etc.

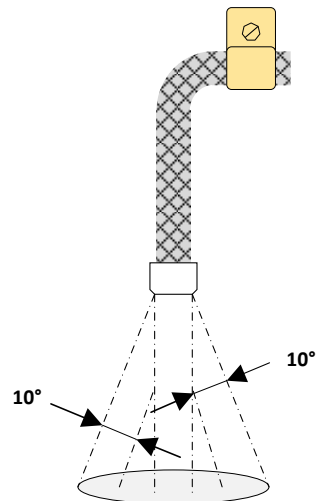

Figure 15

In marine application the exhaust will exit out of the hull of the vessel via the skin fitting. It is important that the end of the exhaust exits in a 'swanneck' to prevent any water from traveling up the exhaust and into the heater.

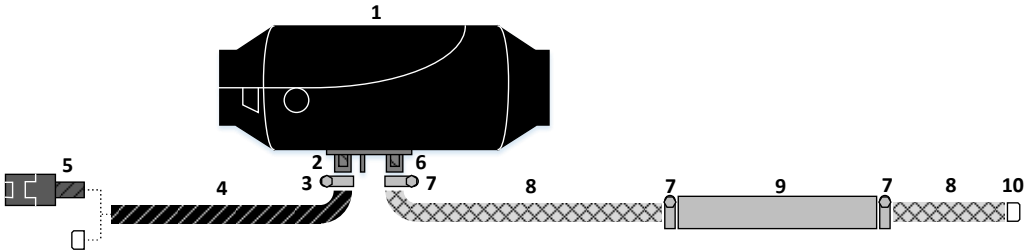

Figure 16

- | | |
|--|------------------------------|
| 1. Heater Body | 2. 25mm Combustion Air Inlet |
| 3. Combustion air inlet clamp | 4. Combustion air pipe |
| 5. Combustion air silencer/filter OR end cap | 6. 24mm Exhaust outlet |
| 7. Exhaust clamp | 8. 24mm Exhaust pipe |
| 9. Exhaust silencer | 10. Exhaust end cap |

Combustion Air Intake

Like the exhaust pipe the combustion air intake can be shortened to up to 20cm or lengthened to no more than 2m, again depending on installation conditions.

In some situations, an air filter is recommended to stop dust or debris making its way up the air pipe.



Installation: Fuel Lines

Note: When installing, priming, repairing fuel lines etc. there is always a risk of injuries due to flammable and toxic sources. Take all the necessary safety precautions when fitting any fuel line or fuel line parts.

DO NOT:

- Smoke
- Use naked flames
- Inhale fumes

When working on or near any fuel lines or parts!

DO:

- Ensure the engine and heater are switched off before attempting any and all work on the fuel line installation or repair.
- Cut any fuel line with a sharp knife to ensure a clean cut free from crushes and burrs.
- Make sure the pipe from the fuel pump to the heater is on a gradual rise.
- Ensure fuel pipes are fastened safely to prevent noise rattle and securely fitted to prevent any damage.
- Route the fuel pipes so that vehicle vibration and movement will not have any lasting effects on the service life.
- Route the fuel line away from **any and all heat sources**, ensuring adequate clearing from them. If it cannot be avoided; use a suitable heat shield.
- Make sure all connectors are fastened securely to prevent dripping of fuel, particularly onto hot surfaces or electrical components.

Fuel Line Connectors

When connecting fuel pipes into rubber connectors always mount them flush and not on a bend to prevent air bubbles from forming in the fuel line as shown in Figure 17.

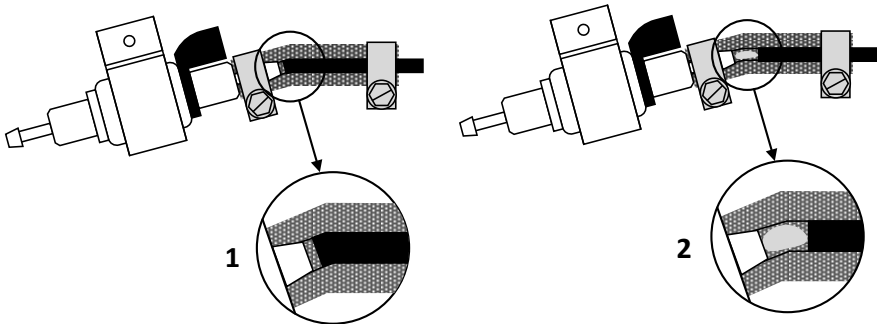

Figure 17

A fuel filter must be fitted for all diesel heaters. Make sure that it is installed the correct way according to fuel flow as shown in figure 18.

Note: Fuel filter, pipes and clamps should be replaced after 2 years.

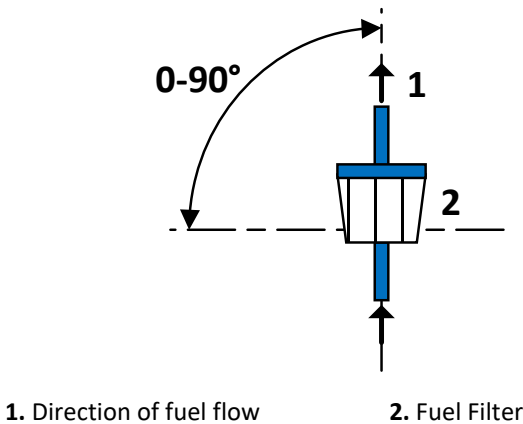

Figure 18

Fuel Line Length and Order

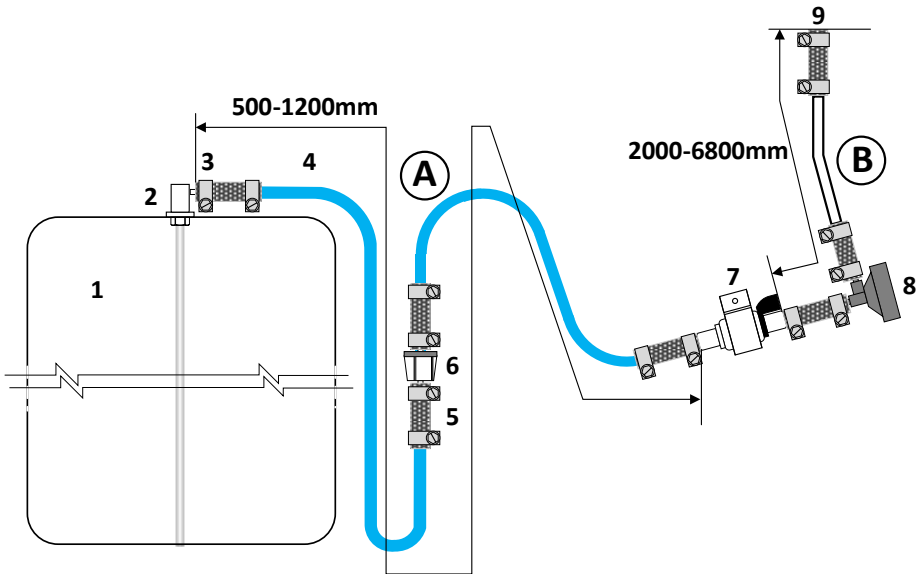

Figure 19

- | | |
|--|----------------------|
| 1. Fuel tank | 2. Fuel Standpipe |
| 3. Fuel connector hose clip | 4. Fuel Line |
| 5. Rubber fuel line connector | 6. Fuel Filter |
| 7. Fuel pump with anti-vibration mount | 8. Damper (optional) |
| 9. Heater body | |

A. Blue Plastic Fuel Line

B. Clear plastic Fuel Line

Copper fuel line should be used for inland waterways installations.

Figure 19 shows how to install parts of the fuel line in the correct order.

Fuel Pump Angle for Installation

Note: Fuel line is best installed straight/upward toward heater at fuel pump end. A damper is only necessary in kits that include one (larger kilowatt heaters).

Always mount the fuel pump with the pressure side rising upward. The preferred position is shown in figure 20 and should be between 15° and 35° .

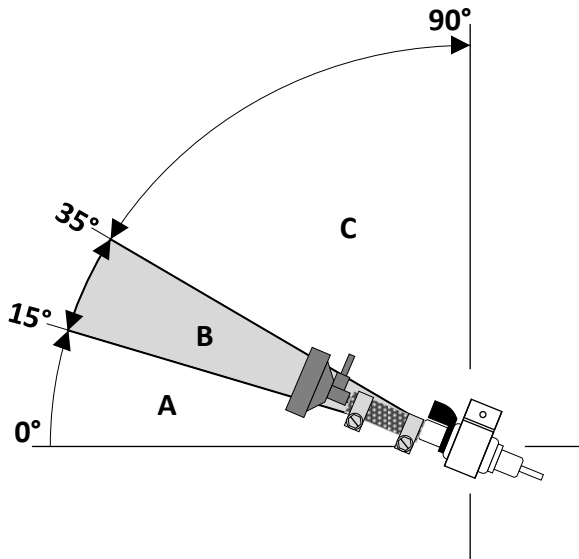
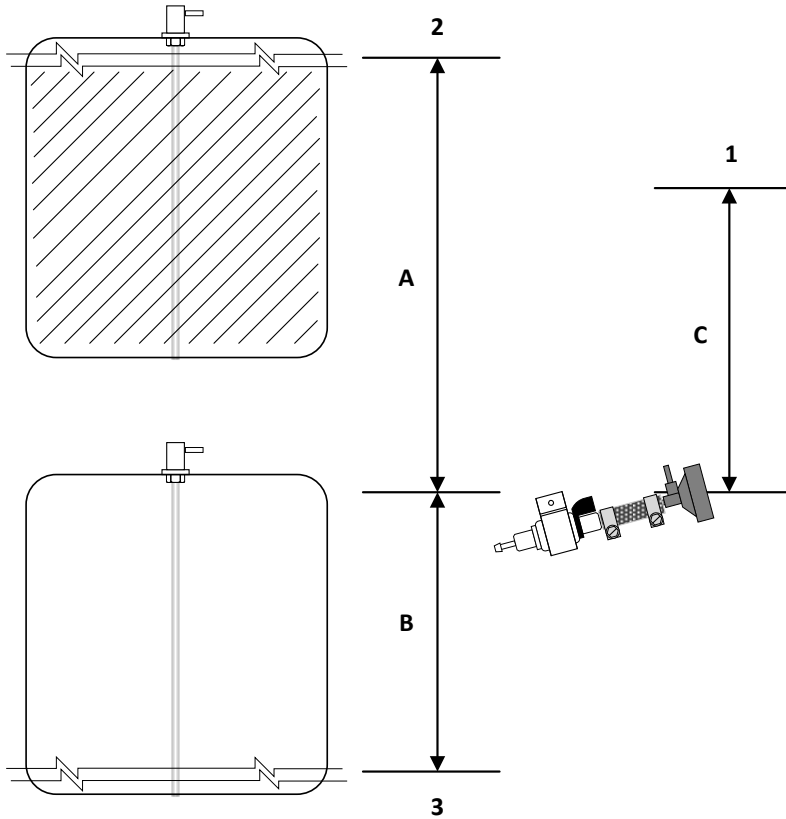

Figure 20

- A.** Between 0° and 15° - Not acceptable
- B.** Acceptable installation position: Between 15° and 35°
- C.** Between 35° and 90° - Not acceptable

Fuel Tank Head



- 1. Connection to heater body
- 3. Minimum fuel level

- 2. Maximum fuel level

Suction height for fuel pump:

- A. 3000mm
- C. 2000mm

- B. 1000mm (diesel) 500mm (petrol)

Figure 21

Fuel Standpipe

A fuel standpipe (or suction pipe) will need to be installed in the vehicle's fuel tank or an independent fuel tank depending on what the installation calls for. Sealant is not required to fit the standpipes.

Depending on the standpipe provide in the kit you will need to install the standpipe in one of two ways.

Standpipe 1: (**Part No:** AHZ-034)

Figure 22

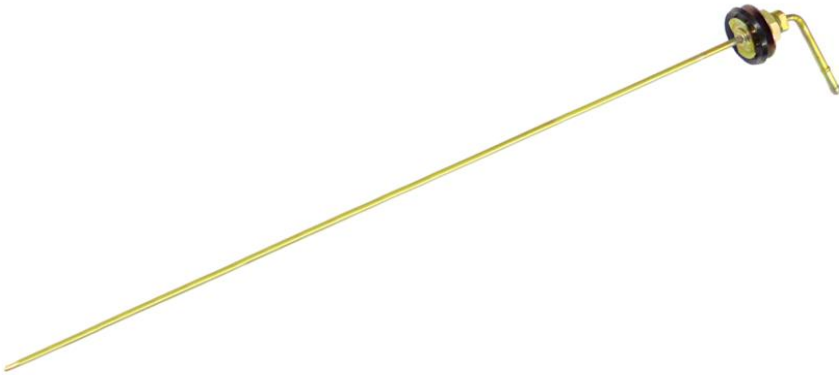

Usually supplied in Marine kits and supplied bent, this standpipe is installed like so:

- Drill a hole in the top of the vehicle's fuel tank $\Phi 22 \pm 0.2\text{mm}$ in size. Ensure it is smooth and clean of burrs.
- Remove the top nut and washers and bend the standpipe straight.
- Cut the standpipe down to size if necessary.
- Fit the standpipe by tilting it into position into the newly drilled hole.
- Place the rubber and metal washers back on top followed by the nut and tighten it securely on top.

Standpipe 2 (Sender Unit Pipe): (**Part No:** AHZ-035)



Figure 23

Supplied mainly in vehicle kits, this standpipe (or sender unit pipe) is installed like so:

- If possible; remove the sender unit from the vehicle's fuel tank, this will make it easier to attach the nut securely back onto the standpipe.
- Drill a $\Phi 6 \pm 0.2\text{mm}$ hole into the sender unit.
- Remove the nut from the standpipe and feed it through the hole ensuring the rubber 'o' ring remains on the standpipe 'head' side.
- Replace the nut on the standpipe to secure it safely to the sender unit.
- Replace the sender unit into the fuel tank.
- To use in a marine application, simply tap an M6 hole into the fuel tank and screw the standpipe inside with the rubber O-ring present.

The bottom of the fuel standpipe should be 30-40mm from the bottom of the fuel tank to allow enough suction of fuel and at the same time not allow impurities and sediment to be drawn up the standpipe.

Electrics: Components

Make sure that all electrical components are arranged in the vehicle so that they function correctly under normal heater operations. Firstly, ensure that no wires are damaged in any way and avoid feeding them through areas that may cause damage to the loom or cause kinking, jamming or exposure to heat. If necessary, fit rubber grommets and plugs around the loom in areas that are not waterproof or may get damaged by road debris, or burrs. Lastly make sure all connections are free of corrosion and all firmly connected.

Airo 2 Boost & 4 Main Connector

The main connector on the loom uses a latch fitting. Pull out the latch from the multiplug on the loom and fit the heater's multiplug inside, paying attention to the orientation of the plug. When the multiplug fits all the way inside, push the latch back into position, securing both plugs together.

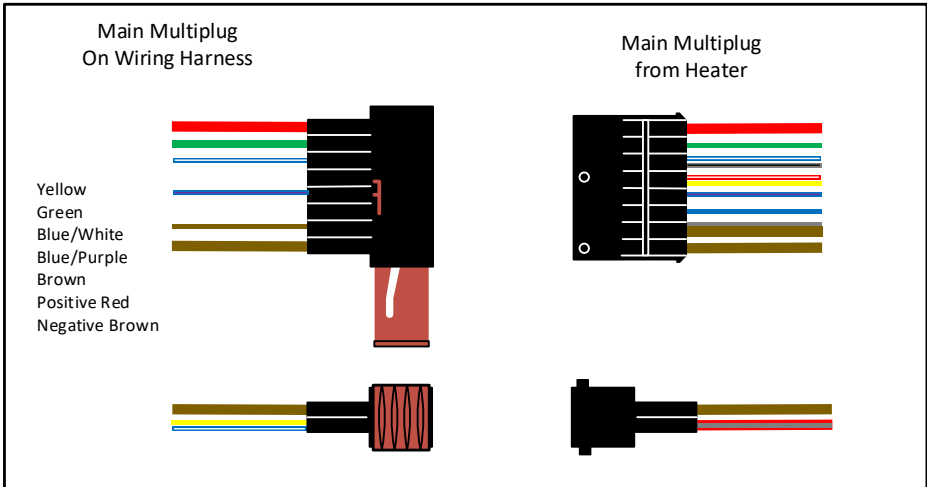

Figure 24

Control Unit Connector

Fix the control unit in place using the methods provided in their respective manuals. They are best installed so that they can be seen and operated easily to identify working conditions and for easy access.

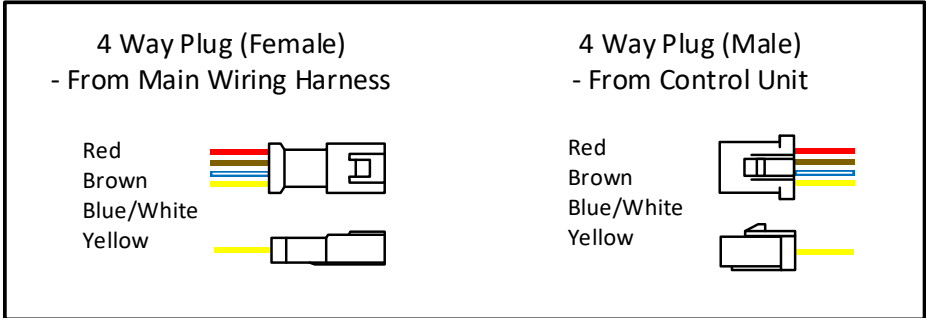

Figure 25

Accessory Plug Connector

The accessory plug is used for optional parts like the mobile phone GSM module. If no such accessory is being used, then this can remain safely unplugged.



Figure 26

Auxiliary Unused Connection

The following plug on the loom can remain safely disconnected.

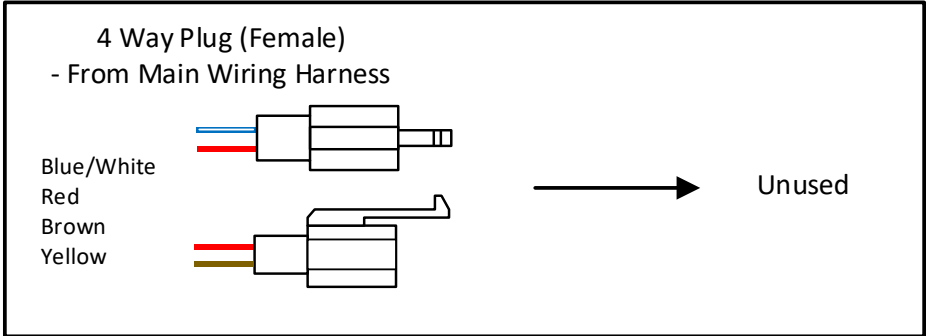

Figure 27

Temperature Sensor Probe Connector

The temperature probe is for use in the controller's thermostatic mode. It measures the ambient temperature and relays the information to the control unit.

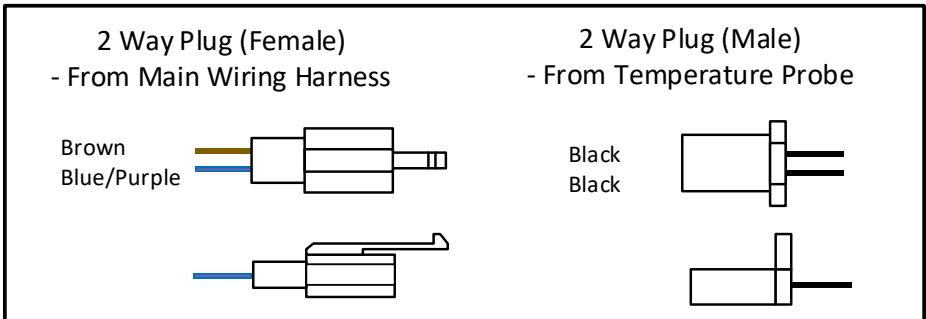

Figure 27

Installing Temperature Probe

We recommend installing the temperature sensor in the following way to maintain a steady room temperature:

- Do not subject it to direct heat.
- Install it at shoulder height when sat in vehicle
- Install it on a vertical wall. The room temperature sensor must be completely exposed to the ambient air.
- Avoiding any external heat sources like stoves, fridges, or direct sunlight.

1. Drill a 10mm hole.
2. Feed the end of the cable with the one insulated connector through the drill hole.
3. Connect the cable to the sensor, regardless which side, as polarity is not an issue.
4. Insert the room temperature sensor. Plug into the main wiring harness as per figure 25.

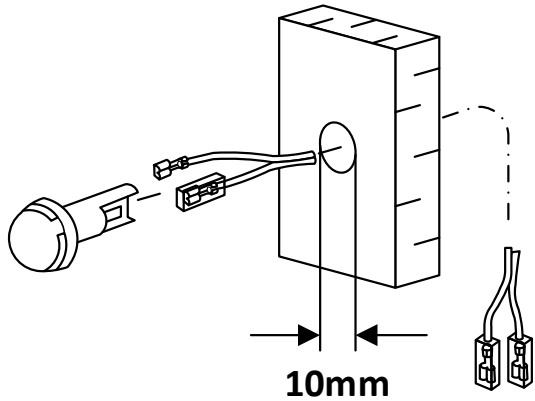

Figure 28

If necessary, the connector cable can be extended using cables (2 x AWG 20 (2 x 0.5 mm²)). However, the overall length must not exceed 10m (33ft).

Note: The temperature probe is not required with systems that use the OLED control, as the OLED control has a temperature sensor inbuilt.

ECU Connections

The connections on the E.C.U. are designed in such a way that wrong connections are difficult to make. Excessive force is the only way wrong connections can be made.

The following circuit interfaces can be found on the ECU; these are:

- GS = Glow Pin (White + Brown)
- FW = Overheat and Flame sensor (Green + Brown)
- UeF = Overheat and flame sensor (Blue)
- BM = Air Motor (Red + Yellow + Brown + Blue)

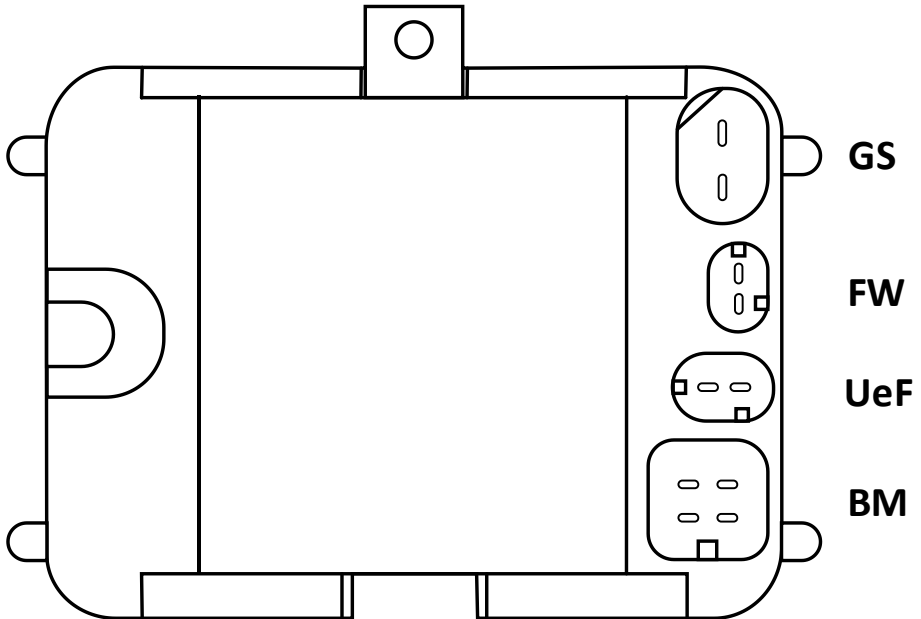

Figure 29

Wiring Diagram

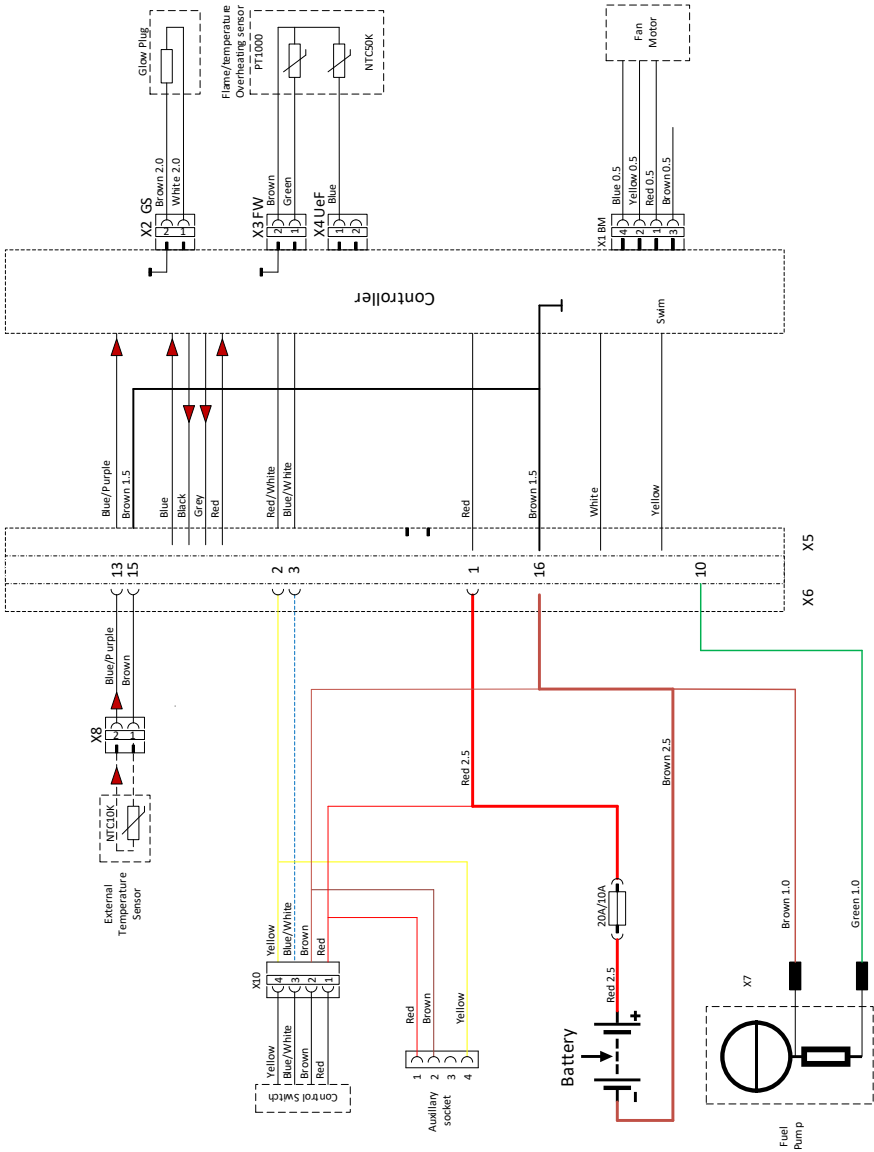

Figure 30



Maintenance

Once the heater is installed, it should ideally be turned on a few times to remove any air trapped in the fuel lines. Also ensure there is no leaking from the lines and that all electric terminals fit securely together.

You should also regularly:

- Check the air inlet and outlet for any pollution or foreign matters.
- Clean the externals of the heater.
- Check for corrosion or loose connections of the circuits.
- Check the combustion air inlet and exhaust pipe for damage and clogs.
- Check the fuel line for leaks.

To ensure a long life of the heater it is advised that you run it for at least 10 minutes every month, to prevent malfunction of mechanical parts.

After 10 years the heat exchanger, overheat sensor and exhaust should be replaced by a professional.

If any welding is being attempted on the vehicle, please remove the positive power supply wire and earth it to protect the controller from any damage.



Fault Codes

Code on Digital/OLED Control	Error Description	Error Light (Flashing Light) on Rotary Control
00	No Fault	
10	Second start failure	F01
20	Heater does not light in time	F02
21	Combustion termination	
30	Voltage too high	F03
31	Voltage too low	
A9	Voltage too low	
41	Overheated	F10
50	Flame sensor open circuit	F05
51	Flame sensor short circuit	
52	Hot air sensor open circuit	
53	Hot air sensor short circuit	
54	Hot air sensor overheated	
65	Inside temperature sensor broken circuit	F06
66	Inside temperature sensor short circuit	
68	Outside temperature circuit broken circuit	
69	Outside temperature circuit short circuit	
70	Fuel pump short circuit	F07
71	Fuel pump broken circuit	
80	Fan broken circuit	F08
81	Fan short circuit	
82	fan speed too low	
83	Fan speed too high	
84	Fan speed measurement fault	
85	Fan motor failure to start	
90	Glow pin open circuit	F09
91	Glow pin short circuit	
92	Glow pin high resistance	
93	Glow plug drive open circuit	
a2	Overheating	F10
b4	Overheating or sensor fault	F11
b5	Overheat sensor fault	
c0	Hydro only - blower relay open circuit	F12
c1	Hydro only - blower relay short circuit	
c4	Preheating temperature broken circuit	
c5	Preheating temperature short circuit	
d0	Crystal oscillator in ECU broken	F13
d1	Fault information storage failure	
d3	Maintenance reminder	
-	Earthing Issue	Constant Flash
-	Connection/Communication Error	Traffic Light

+44 (0)23 8052 2345

