



# MV Airo 2

WORKSHOP MANUAL

Ed 1.03

MV Heating UK Ltd  
Unit 6  
Second Avenue Business Park  
Millbrook  
Southampton  
SO15 0LP

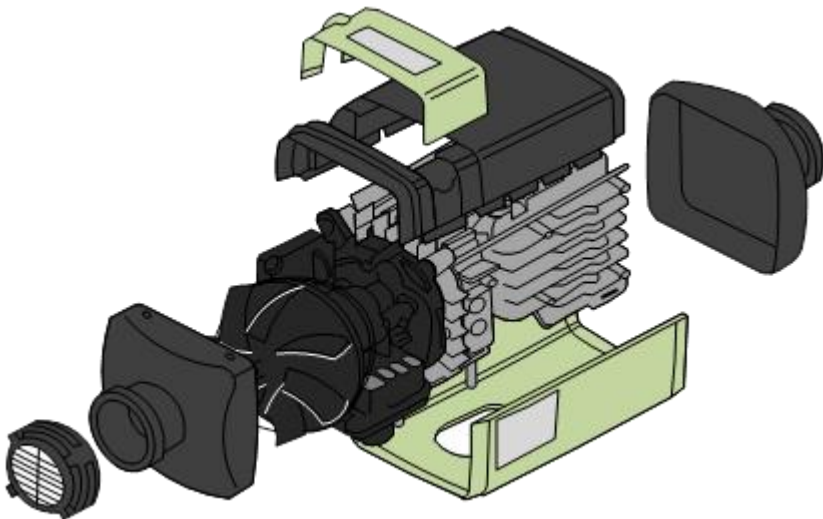

MV Heating UK LTD  
+44 (0)2380 522345



## **Disclaimer:**

This manual is intended to give an overview of the internal workings of MV diesel heaters. As such, all work should be carried out by trained professionals at their own discretion. Any action you take upon the information in this manual is strictly at your own risk, and MV Heating will not be liable for any losses and damages in connection with the use of this information. Under no circumstances shall MV Heating or its affiliates, suppliers, or installers be liable for any indirect, incidental, consequential, special or exemplary damages, arising out of or in connection with these manuals. We do not take any warranties about the completeness, reliability and accuracy of this information. MV Heating assumes no responsibility or liability for any errors or omissions from these manuals.

Service intervals should be taken roughly every 1,500 hours.

Check over unit, dismantle and then replace what is necessary from visual inspection.



## Contents

Heater Removal .....	3
Heater Installation .....	3
Heater Cases Diagram .....	4
Internal Structure Diagram .....	5
ECU Connections Diagram .....	6
Removing and Refitting of Parts .....	7
Pre-Checks and Notes .....	7
Part 1: The Case Assembly .....	8
Part 2: The Overheat Sensor .....	9
Part 3: The E.C.U. ....	10
Part 4: The Air Motor .....	11
Part 5: Burner, Glow Pin, and Combustion Chamber .....	12
Part 5 Cont'd: Burner, Glow Pin, and Combustion Chamber .....	13
Part 5 Cont'd: Burner, Glow Pin, and Combustion Chamber .....	14
Part Numbers .....	15
Notes .....	16

**Note:** The following flow charts will refer to the exploded diagrams, or figures as (F:P), where 'F' donates the figure, and 'P' donates the part in that figure. For example (2:4) would mean 'Figure 2: Part 4'.



## Heater Removal

To remove the heater from its installation positions, follow these steps:

1. Disconnect the vehicle's battery.
2. Disconnect any ducting secured to the heater's inlet, or outlet caps.
3. Remove the E.C.U. cover (**1:3**) from the top cover (**1:4**) to access the main heater connection.
4. Disconnect main wiring harness connector from heater.
5. Disconnect the fuel supply line from heater's fuel inlet.
6. Disconnect the fuel pump by **pressing the spring clip down** and pulling away the connector.
7. Disconnect the combustion air intake and exhaust pipe from the bottom of the heater.
8. Remove the four M6 nuts and washers from the base of the heater.
9. Remove the heater and discard the mounting gasket.

## Heater Installation

To reinstall the heater back into position, follow these steps:

1. Locate heater into position with a new mounting gasket and secure with the four M6 nuts and washers to 6 + 1 Nm.
2. Connect and secure fuel supply line to the heater's fuel inlet.
3. Connect and secure the combustion air intake and exhaust pipe to the heater.
4. Route the fuel cable to the fuel pump and reconnect it.
5. Connect the main wiring harness connector to the E.C.U. and replace the cover (**1:3**).
6. Reconnect the vehicle's battery.
7. Fully bleed the fuel supply system, by turning the heater on and off. Ignition failure will occur until the system has been bled.

## Heater Cases Diagram

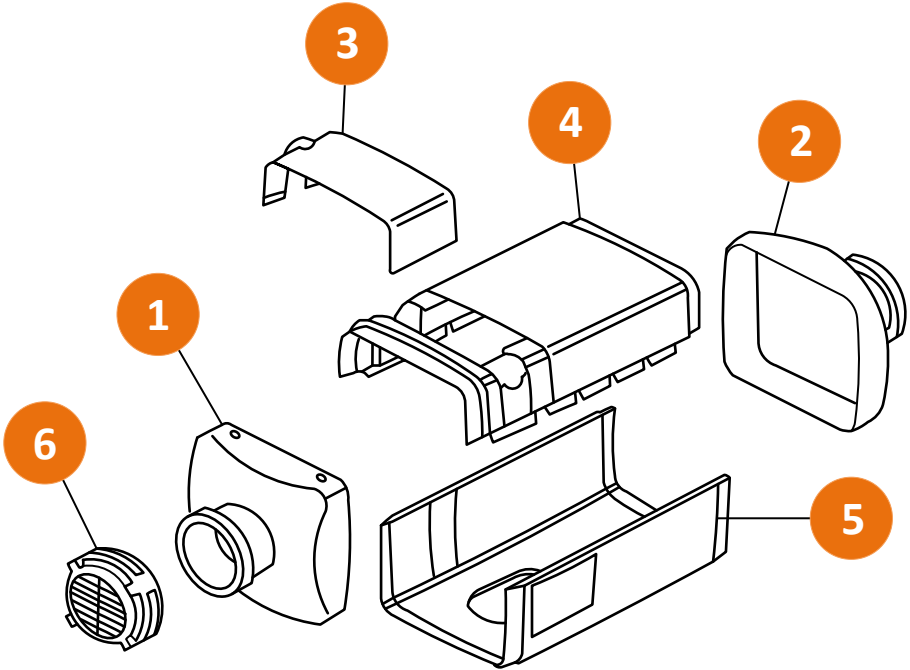

**Figure 1**

**1. Inlet Cap**

**2. Outlet Cap**

**3. E.C.U. Cover**

**4. Top Cover**

**5. Bottom Cover**

**6. Grill**

## Internal Structure Diagram

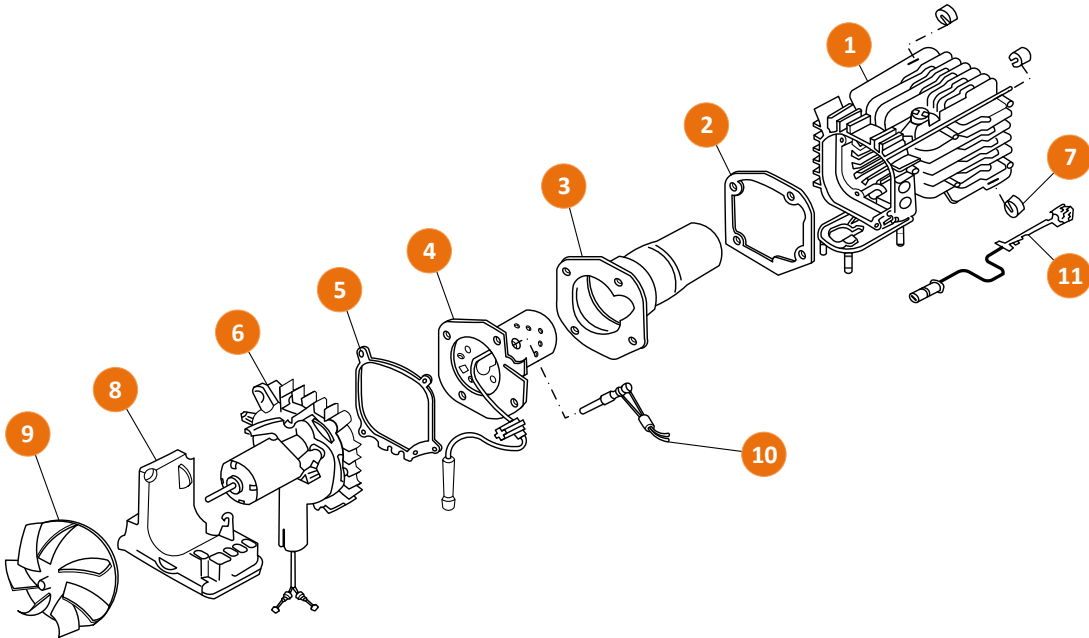

**Figure 2**

**1.** Heat Exchanger

**2.** 4-Hole Gasket

**3.** Combustion Tube

**4.** Burner Assembly

**5.** 5-Hole Gasket

**6.** Air Motor

**7.** Insulation Bushes

**8.** E.C.U.

**9.** Air Fan

**10.** Glow Pin

**11.** Overheat Sensor

## ECU Connections Diagram

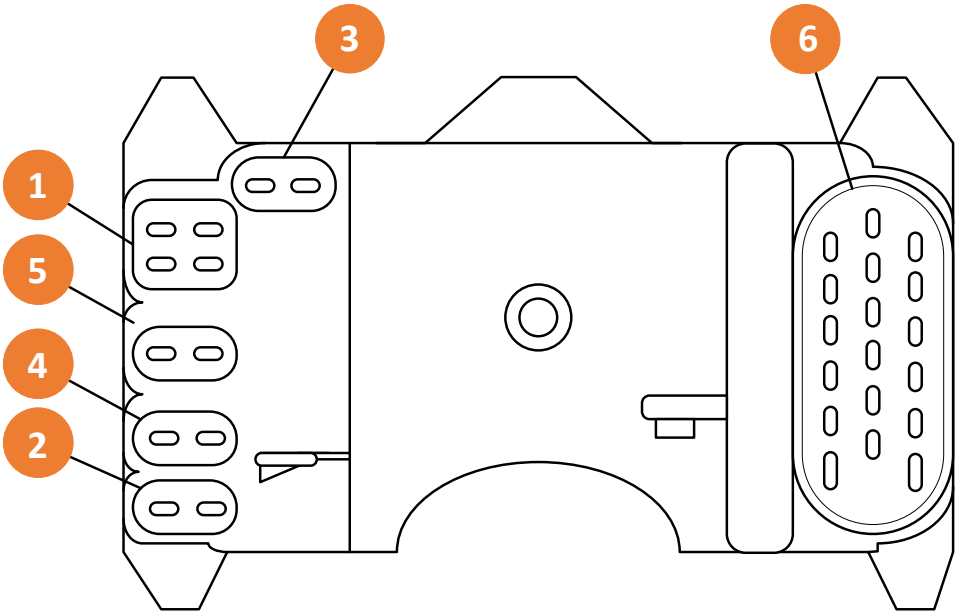

**Figure 3**

**1.** Fan Motor

**2.** Glow Pin

**3.** Overheat Sensor

**4.** Fuel Pump

**5.** Unused

**6.** Main Wiring Harness



## Removing and Refitting of Parts

### Pre-Checks and Notes

- All gaskets located between the disassembled parts must always be discarded and replaced.
- All the parts that have been disassembled should be cleaned with appropriate cleaning fluid and blown dry with pressurized air.
- Any sealing compound on parts must be carefully and completely removed before attempting to refit.
- All disassembled parts should be Inspected for damage (cracks, distortion, wear, etc.) and replaced as required.

You should also regularly inspect all electrical connectors and wiring for corrosion, loose contacts, or wrong crimping, etc. and repair as required.

## Part 1: The Case Assembly

### Tools:

- 1 x Small Flat-Bladed Screwdriver

### Removing the Cases:

- 1) Remove the heater from its installation position.
- 2) Remove the inlet cap (**1:1**) using a small flat-bladed screwdriver to separate from bottom and top cases.
- 3) Remove the outlet cap (**1:2**) the same way.
- 4) Remove the top case (**1:4**) by sliding away from the bottom case.
- 5) Remove the bottom case (**1:5**) by pulling away from air motor lugs first.

### Refitting the Cases:

- 1) Make sure all 4 insulating bushes (**4:7**) are located on the heat exchanger (**2:1**).
- 2) Replace bottom case, ensuring the air motor lugs sit inside the appropriate holes.
- 3) Replace top case, ensuring that the tabs are located inside the bottom case correctly.
- 4) Refit the outlet cap, ensuring that it is orientated correctly.
- 5) Refit the inlet cap, ensuring that it is orientated correctly.



## Part 2: The Overheat Sensor

### Tools:

- 1 x Small Flat-Bladed Screwdriver

### Removing the Overheat Sensor:

- 1) Remove the cases (**Part 1**).
- 2) Unplug the overheat sensor (**2:11**) from the E.C.U. (**2:8**) (two blue wires).
- 3) Free the wires from around the E.C.U. hook.
- 4) Slide the overheat sensor off the heat exchanger (**2:1**). Using a small flat-bladed screwdriver as necessary to lever it off.

### Refitting the Overheat Sensor:

- 1) Replace the overheat sensor on the heat exchanger.
- 2) Feed the wires back under the E.C.U. hook to secure them in place.
- 3) Plug the overheat sensor back into the E.C.U. paying attention to its correct orientation.



### Part 3: The E.C.U.

#### Tools:

- 1 x 3mm Hex Key

#### Removing the E.C.U.:

- 1) Remove the cases (**Part 1**).
- 2) Remove the air fan (**2:9**) by inserting a large flat-bladed screwdriver between the top of the air fan and the air motor spigot, twisting gently and pulling to separating the two.
- 3) Remove all connections from the E.C.U. (**2:8**).
- 4) Remove the 3 x Phillips head screws holding the E.C.U. in place.
- 5) The E.C.U. can now be removed, inspected and replaced as necessary.

#### Refitting the E.C.U.:

- 1) Place the E.C.U. back into position and tighten the 3 x Phillips head screws back into position at  $0.7 \pm 0.07$  Nm.
- 2) Reconnect all the connections paying attention to their orientations – They will only plug in one way, **do not** force them.
- 3) Push the air fan back onto the shaft, look for the flat edge on the air fan, and the flat edge of the air motor spigot to connect the two.
- 4) Check the fan spins freely and reconnect the overheat sensor (**Part 2**), and the cases (**Part 1**).



## Part 4: The Air Motor

### Tools:

- 1 x 4mm Hex Key

### Removing the Air Motor:

- 1) Remove Cases (**Part 1**) and E.C.U. (**Part 3**)
- 2) Remove the 5 x bolts located around the bottom of the air motor (**2:6**)
- 3) Carefully remove the air motor, tilting it to one side so that the combustion intake clears the gap on the heat exchanger (**2:1**).
- 4) The air motor gasket (**2:5**) can be removed and discarded once the air motor is clear

### Refitting the Air Motor:

- 1) Place a new air motor gasket around the end of the heat exchanger.
- 2) Refit the air motor back into position.
- 3) Place the earth cable over the top right hex bolt, and fit the remaining 4 x hex bolts around the base of the air motor and tighten to  $4.0 \pm 0.4$  Nm.
- 4) Refit E.C.U. (**Part 3**) and cases (**Part 1**).



## Part 5: Burner, Glow Pin, and Combustion Chamber

### Tools:

- 1 x Small Flat-Bladed Screwdriver
- 1 x 5.5mm Socket Screwdriver
- 1 x Small Phillips Head Screwdriver

### Removing the Assembly:

- 1)** Remove the cases (**Part 1**) remove the E.C.U. (**Part 3**) and remove the air motor (**Part 4**).
- 2)** Gently push the glow pin grommet fully through toward the burner.
- 3)** Using an Allen key, remove the 4 x 3mm hex bolts from the burner (**2:4**), and place to one side.
- 4)** The burner and combustion chamber (**2:3**) will be connected to each other and can be partially lifted out of the heat exchanger.
- 5)** Separate the two using a small flat-bladed screwdriver and remove both parts from the heat exchanger (**2:1**).
- 6)** Remove the 4-hole gasket (**2:2**) from inside the heat exchanger and discard.



## Part 5 Cont'd: Burner, Glow Pin, and Combustion Chamber

### Tools:

- 1 x Small Flat-Bladed Screwdriver
- 1 x 5.5mm Socket Screwdriver
- 1 x Small Phillips Head Screwdriver

### Glow Pin Removal:

- 1)** Once the burner has been removed, use a Phillips head screwdriver to loosen the screw holding the glow pin (**2:10**) in place.
- 2)** Gently remove the glow pin from out of its housing (the glow pin can be tight to remove), and out of the slit in the burner assembly.
- 3)** The burner and glow pin can now be inspected, cleaned or replaced as necessary.

### Refitting the Glow Pin:

- 1)** Feed the glow pin back through the appropriate slot on the burner and reinsert it fully into position.
- 2)** Tighten the small Phillips head screw onto the glow pin to  $0.8 \pm 0.08$  Nm to hold it securely in place.
- 3)** Gently move the glow pin back up and into the slit in the burner assembly.
- 4)** Pull the glow pin cable gently to ensure it is flush against the heat exchanger and burner, preventing it from rubbing on the combustion air fan.



## Part 5 Cont'd: Burner, Glow Pin, and Combustion Chamber

### Tools:

- 1 x Small Flat-Bladed Screwdriver
- 1 x 5.5mm Socket Screwdriver
- 1 x Small Phillips Head Screwdriver

### Refitting the Assembly:

- 1)** Refit a new 4-hole (burner) gasket (**2:2**).
- 2)** Place the combustion chamber the right way up inside the heat exchanger.
- 3)** Place the burner assembly inside the combustion chamber, and reinsert the 3 x 5.5mm hex screws back into the burner and tighten to  $0.6 \pm 0.06$  Nm.
- 4)** Feed the glow pin lead back through the correct hole and push the grommet so that it is flush with the cut-out.
- 5)** Push the fuel inlet grommet back into position ensuring it is flush with the heat exchanger.
- 6)** Refit the air motor (**Part 4**), the E.C.U. (**Part 3**), the overheat sensor (**Part 2**), and the cases (**Part 1**).



## Part Numbers

<b>Part (Voltage)</b>	<b>Part Number</b>
1) Heat Exchanger:	A2Z-001
2) 4-Hole Gasket:	A2Z-002
3) Combustion Tube:	A2Z-003
4) Burner Assembly:	A2Z-004
5) Burner Assembly Alpine Auto-K:	A2Z-004-K
6) 5-Hole Gasket:	A2Z-005
7) Air Motor (12V/24V):	A2C-006/A2A-006
8) Insulation Bushes:	A25Z-007
9) E.C.U. (12V/24V):	A2C-009/A2A-009
10) E.C.U. Alpine Auto (12V/24V)	A2C-009-AA/A2A-009-AA
11) Air Fan:	A2Z-010
12) Glow Pin (12V/24V):	A2C-014/A2C-014
13) Glow Pin Alpine Auto-K (12/24V):	A2C-014-K/A2A-014-K
14) Overheat Sensor:	A25Z-016
15) Inlet Cap:	A2Z-027
16) Outlet Cap:	A2Z-028
17) E.C.U. Cover:	A2Z-024
18) Top Cover:	A2Z-025
19) Bottom Cover:	A2Z-026
20) Grill:	A2Z-029
21) Fuel Pump (12V/24V)	AHC-023/AHA-023



## Notes

.....

.....

.....

.....

.....

.....

.....

.....

.....

.....

.....

.....

.....

.....

.....

.....

.....

.....

.....

.....

.....

.....

.....

+44 (0)23 8052 2345



+44 (0)23 8052 2345

