

MV Airo 2 Boost and Airo 4



NON-PLATEAU

AIR HEATERS

INSTRUCTION MANUAL

ED 1.02

MV Heating UK Ltd
Unit 6
Second Avenue Business Park
Millbrook
Southampton
SO15 0LP



2.2kW and 4kW Air Heaters

MV Heating UK LTD
+44 (0)2380 522345



Preface

Thank you for purchasing the MV Airo 2 Boost or Airo 4 diesel heater (hereinafter referred to as 'the heater'). This manual will attempt to describe the structure, working principle, installation and operation of the heater. For future reference please keep this manual in a safe and convenient place.

Note

- This instruction booklet is subject to revision without notice but the instruction book is in conformity to the purchased product.
- The manual will attempt to answer any and all questions the user may have. If you have and further questions or find anything incorrect within this manual, please contact us directly.
- Please check that the heater is not damaged when first unpacking it and contact the dealer immediately if any problems are found.
- If any problems or faults arise during installation or operation, please contact us directly or any other customer service station authorised by our company. We shall do our best to offer you our full support.



Contents

Uses and Applications	5
Safety Information	6
MV Airo 2 Boost Technical Data	7
MV Airo 4 Technical Data	8
Internal Structure	9
Kit Contents	10
MV Airo 2 Boost Dimensions	12
MV Airo 4 Dimensions	12
Installation:	13
Positions	13
Installation: Angle	15
Wiring Harness Connector Positions	16
Installation: Mounting	17
Installation: Ducting and Pipework	19
Exhaust System	20
Combustion Air Intake	21
Installation: Fuel Lines	22
Fuel Line Connectors	23
Fuel Line Length and Order	24
Fuel Pump Angle for Installation	25
Fuel Tank Head	26
Fuel Standpipe	27



Electrics: Components	29
Control Switch & Timer	29
External Temperature Sensor Probe.....	29
Wiring Diagram	30
Control Connections	31
ECU Connections.....	33
Operation:.....	34
Rheostat Control.....	34
Operation: LCD Digital 7-Day Timer	35
Changing Language	36
Changing the Date and Time.....	37
Manual On/Off.....	38
Switching to Thermostatic Mode.....	39
Fan Mode	39
Pre-setting Heating Times.....	40
Installation Fuel Priming Feature	42
Checking Error Codes	43
Resetting Digital Controller to Factory Settings.....	44
Entering Altitude Mode.....	45
Maintenance	46
Fault Codes:.....	47
Rheostat Control.....	47
Fault Codes: Mini Timer	48

+44 (0)23 8052 2345





Uses and Applications

The heater works independently from the vehicle's engine, but is best fitted using the vehicle's battery and fuel tank. An auxiliary battery and/or fuel tank can be used if necessary.

The heater will operate under normal conditions in most vehicles from industrial and machinery sectors to leisure craft like yachts and motor homes.

The heater is best used for heating various cabins and compartments, engine preheating and glass defrosting.

It is **not recommended** for constant long-term operation for residential rooms, garages, holiday homes etc.

Note:

The most common faults that occur are generally down to poor fuel conditions due to dirty (or empty) fuel tanks or drops in voltage; particularly in older vehicles like live aboard narrowboats or used, commercial vehicles.



Safety Information

Follow the installation guidelines carefully to ensure the heater has the appropriate amount of clearance between surfaces, so as not to become a fire hazard and that the various parts of the heater that get hot, like the exhaust, are not exposed or contaminated by possible fuel and oil.

Sufficient ventilation is required allowing proper air-flow to the heater. If the heater is to be installed in a box or compartment, please ensure an air vent is installed for this reason. The air must also be fresh and not contaminated by exhaust fumes or other polluted sources. Make sure that the air intakes and exhaust do not get blocked by other objects.

Take care to ensure that the exhaust outlet is installed in a way that prevents fumes entering the vehicle or in the direction of the fresh air intake and ensure the use of heat shields where necessary to again avoid fire damage.

If work is to be carried out on or around the heater, turn it off at least an hour before so, so that it is sufficiently cool enough to be handled. If necessary, wear safety gloves.

The fuel line must not be routed through the passenger compartment or the driver's cab in any vehicle. Ensure that they are also installed so that the exits are not at risk or in danger of becoming a possible fire hazard.

Finally, take care and follow any and all precautions when installing the heater to minimize injuries to yourself and damage to the heater.



MV Airo 2 Boost Technical Data

Heat Power (W)	2200
Fuel	Diesel
Output (W)	850 (Min) - 2200 (Max)
Fuel Consumption (l/h)	0.1 - 0.28
Run Time Power Consumption (w)	7 - 20
Weight (kg)	2.7
Working Temperature	-40°C - 20°C

Variable Output	Current Draw
Position	(Amps)
PO1	0.4
PO2	0.5
PO3	0.8
PO4	1.1
PO5	1.6
PO6	2.1
PO7	2.7



MV Airo 4 Technical Data

Heat Power (W)	4000
Fuel	Diesel
Output (W)	900 - 4000
Fuel Consumption (l/h)	0.11 - 0.51
Run Time Power Consumption (w)	8 - 40
Working Temperature	-40°C - 20°C
Weight (kg)	4.5

Variable Output	Current Draw
Position	(Amps)
PO1	0.4
PO2	0.6
PO3	0.8
PO4	1.3
PO5	1.4
PO6	1.9
PO7	2.4

Internal Structure

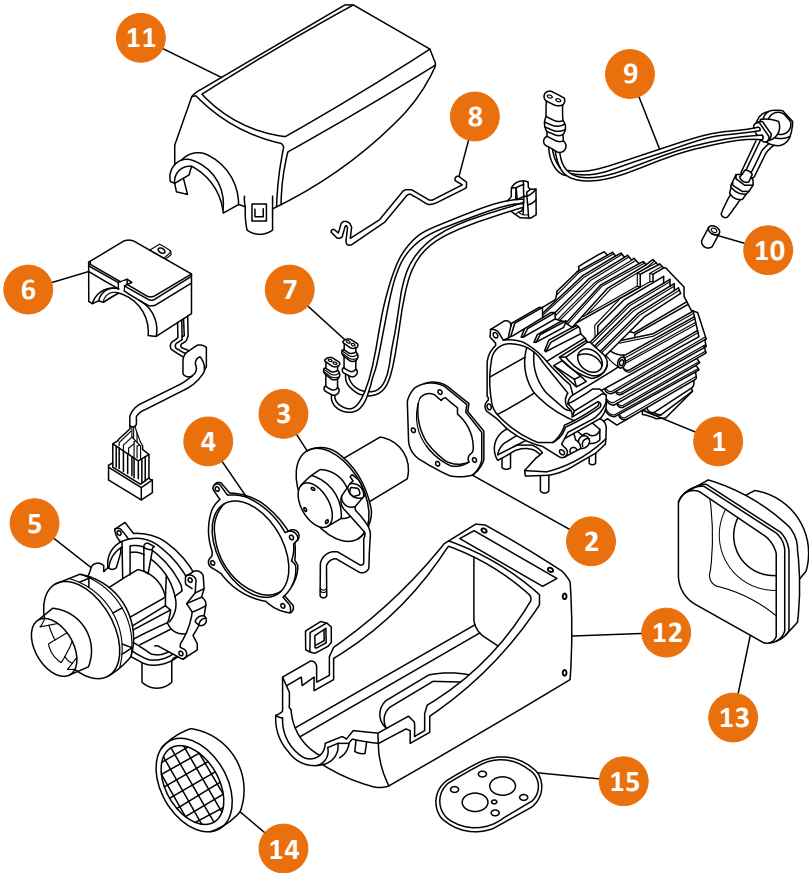

Figure I

- | | | |
|----------------------------|-------------------------|----------------------------|
| 1. Heat exchanger | 2. Burner Gasket | 3. Burner Assembly |
| 4. Air Motor Gasket | 5. Air Motor | 6. ECU |
| 7. Overheat Sensor | 8. Spring Clip | 9. Glow Pin |
| 10. Glow Pin Screen | 11. Top Case | 12. Bottom Case |
| 13. Outlet Cover | 14. Inlet Grill | 15. Mounting Gasket |

Kit Contents

The kit includes everything necessary for installation.

Exploded Parts Diagram

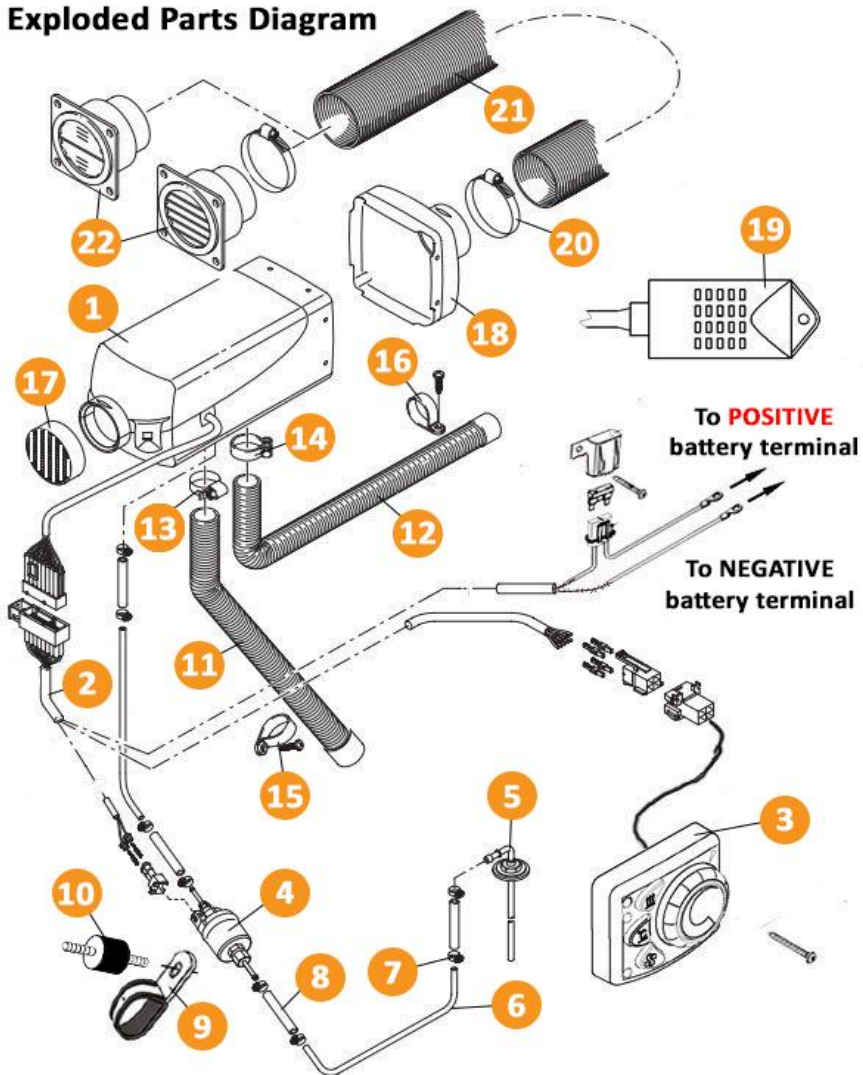

Figure II



- 1.** Main heater unit
- 2.** Main wiring harness
- 3.** Control switch/timer
- 4.** Fuel pump
- 5.** Fuel standpipe
- 6.** Fuel pipe
- 7.** Fuel line connector hose clip
- 8.** Fuel line connector
- 9.** Fuel pump clamp
- 10.** Anti-vibration mount
- 11.** Combustion air pipe
- 12.** Exhaust pipe
- 13.** Combustion air pipe clamp
- 14.** Exhaust pipe clamp
- 15.** Combustion air pipe fixing clamp
- 16.** Exhaust pipe fixing clamp
- 17.** Grill
- 18.** Outlet Cover
- 19.** Temperature probe
- 20.** Hose clip
- 21.** Hot air ducting
- 22.** Outlet vents

MV Airo 2 Boost Dimensions

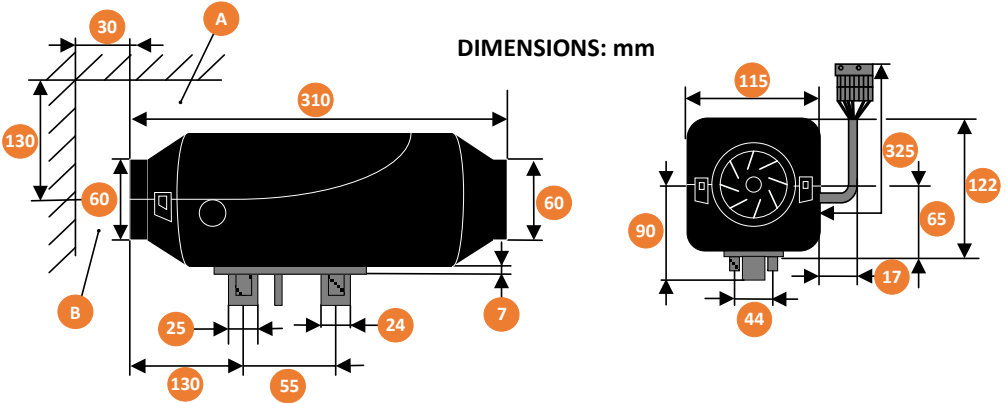

Figure III

MV Airo 4 Dimensions

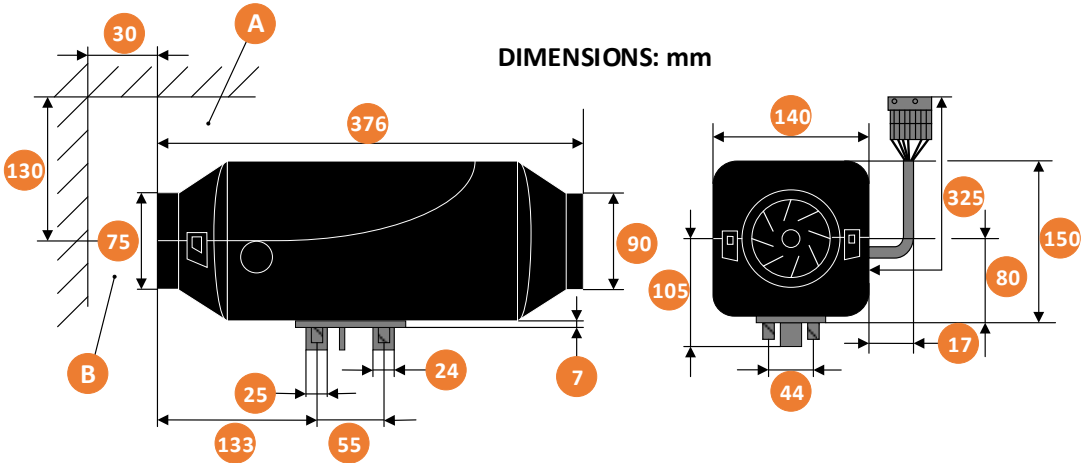

Figure IV

A: Minimum installation clearance for opening the lid and dismantling glow pin and E.C.U.

B: Minimum installation clearance for the air intake

Installation:

Positions

Motorhome

Figure V

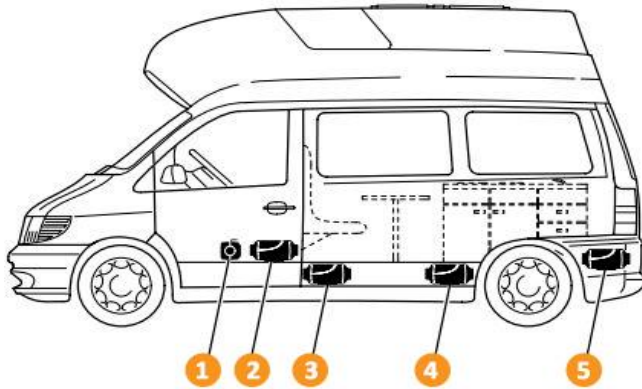

1. In front of the passenger seat
2. Between the passenger and driver's seat
3. Under the vehicle floor
4. Under the rear seat
5. Inside the boot

Minivan

Figure VI

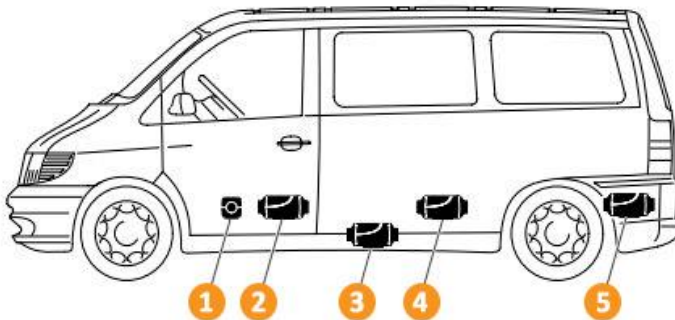

1. In front of the passenger seat
2. Between the passenger and driver's seat
3. Under the vehicle floor
4. Under the rear seat
5. Inside the boot

Industrial

Figure VII

- 1. In seat box
- 2. On the rear wall
- 3. In a protective case



Lorry

Figure VIII

- 1. In passenger footwell
- 2. On the cabin rear wall
- 3. Under the bed
- 4. In the tool box

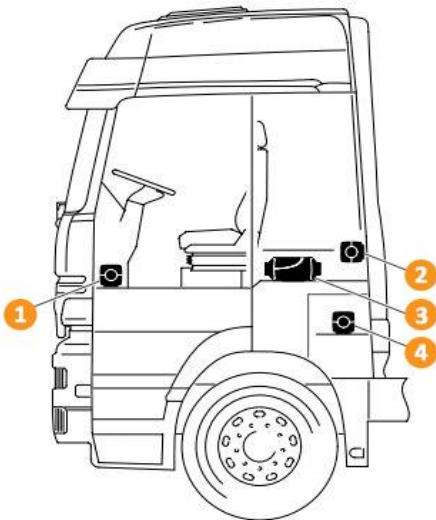

Installation: Angle

All positions suggested are examples. Other locations are possible so long as they correspond to the proper installation guidelines and requirements.

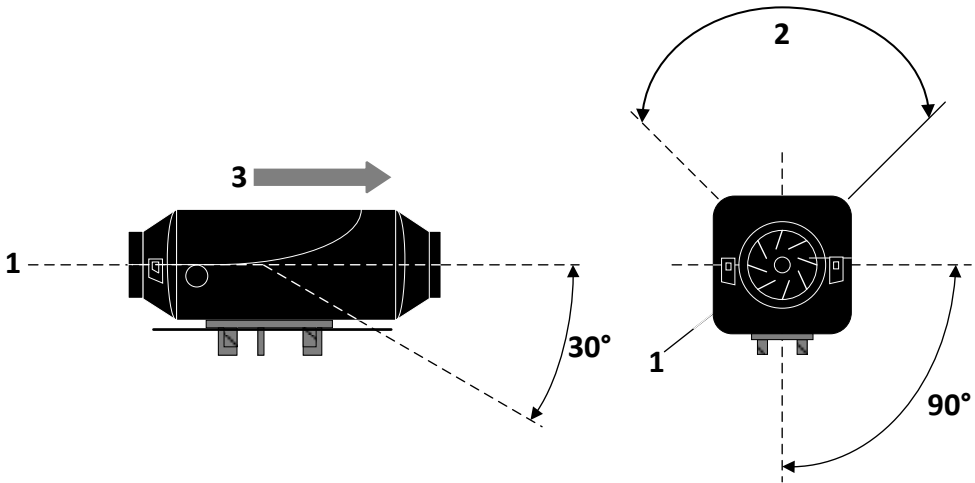

1. Heater air intake 2. Glow pin position 3. Direction of air flow

Figure IX

Figure IX shows the ideal installation position of the heater; with exhaust pointing downward. Depending on its location it can be tilted by 30° with the air flow and hot air outlet facing the bottom. It can also be tilted on its longitudinal axis by 90° so long as the glow pin position points upward. During usual operation the heater can deviate by 15° each way with vehicle movement without impaired function of the heater.

Wiring Harness Connector Positions

The main connector coming off the heater can be moved to the other side of the heater if necessary. In order to do you must first remove the air inlet grill by twisting it so it's clear of its securing lip and then simply pull it off. Next, remove the top cover by lifting up the two front flaps near the air inlet. You can then lift out the entire innards of the heater (heat exchanger to fan motor and all) removing the cable from the rubber securing bush and rerouting it underneath the fan motor where it can then sit in the cut-out on the opposite side. Ensure the rubber bush is properly inserted and the heat exchanger is back securely in position, then simply replace the lid and grill back in position.

Note: Ensure the bottom cover fits correctly inside the groove of the lid.

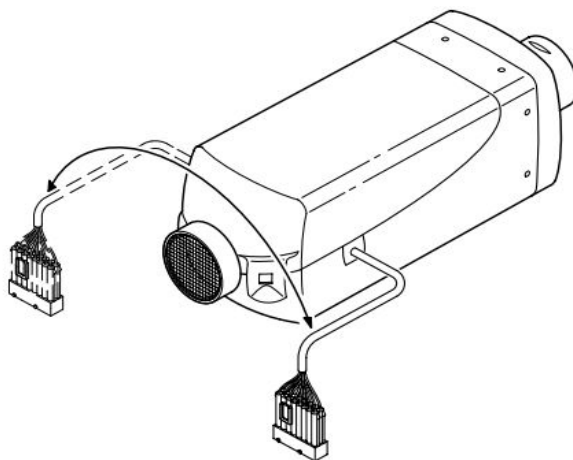
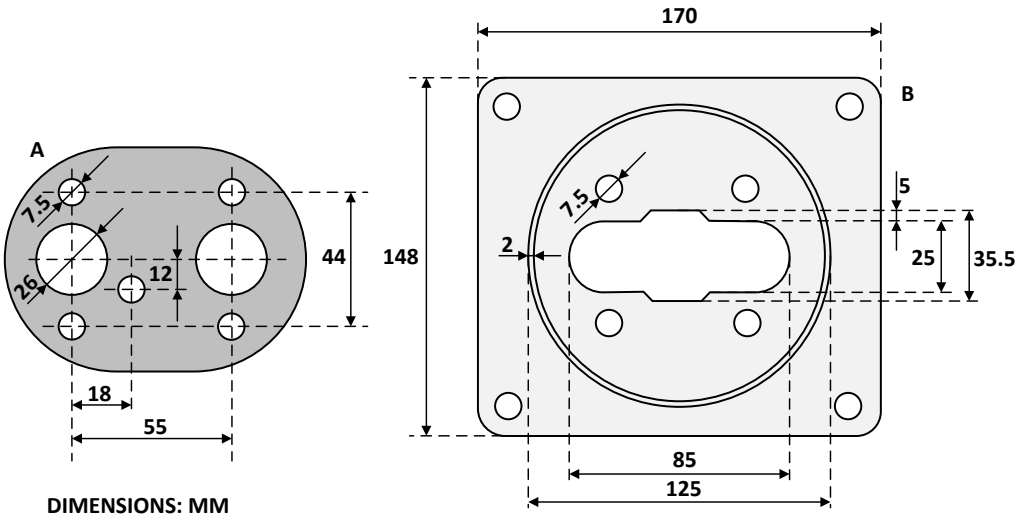

Figure X

Installation: Mounting

The chosen mounting surface should be flat and you will need to drill the appropriate size hole for the exhaust, combustion air inlet, fuel inlet and mounting bolts. It is a good idea to mount the heater on the supplied mounting bracket, particularly if the original mounting surface is thinner than 1.5mm.



A. Mounting Gasket

B. Mounting Plate

Figure XI

Note: The mounting plate shown in figure XI may differ in overall size and the circular flange may not be present, however the heater footprint will remain the same.

Installation: Mounting (Cont'd)

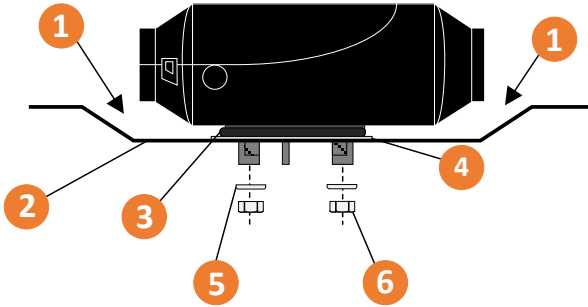

(Above)

Securing the heater to the floor

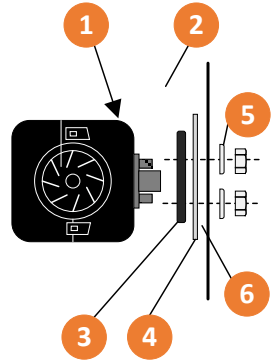

(Above)

Securing the heater to the wall

Figure XII

1. Check that the fan wheel spins freely and that there is sufficient clearance between the heater and the vehicle floor
2. Ensure that the mounting surface is flat and smooth
3. The mounting gasket supplied must be fitted
4. The vehicle wall must be flat and smooth
5. Mounting bracket
6. M6 Washer
7. M6 Nut

Figure XII shows the mounting positions on a vehicle's floor and wall.

Installation: Ducting and Pipework

Using the MV Airo 2 Boost as an example:

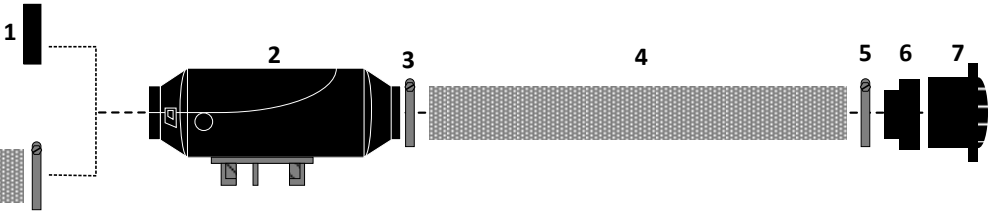

Figure XIII

- 1. Ducting AND/OR Grill
- 2. Main Heater body
- 3. 60mm Hose Clip
- 4. 60mm APK Ducting
- 5. 60mm Hose Clip
- 6. 60mm Reducer
- 7. 80mm Directional Vent

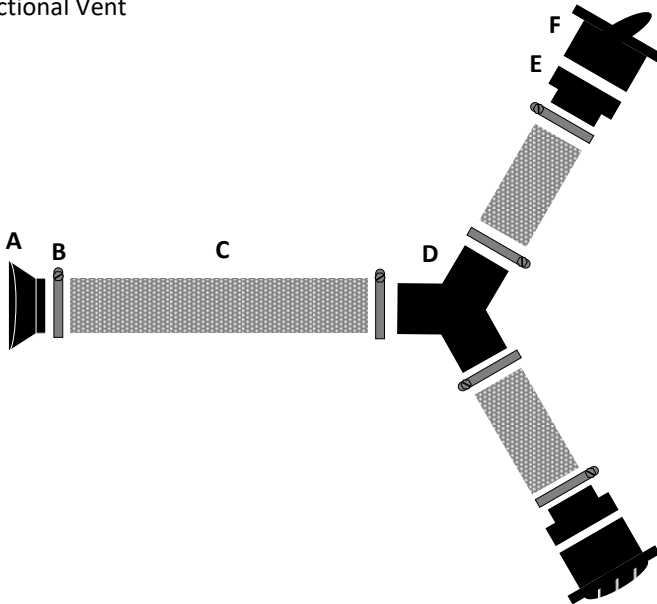

Figure XIV

- A. Heater's hot air outlet
- B. 60mm hose clip
- C. 60mm APK ducting
- D. 60mm 'Y' branch
- E. 60mm Reducer
- F. 80mm outlet vent



Installation: Ducting (Cont'd)

Ducting Can be installed as shown on the previous page. Extra outlets can be installed to fit your own needs however you should ideally not fit more than the maximum of 3 outlets to the Airo 2 Boost, or 4 outlets for the Airo 4, to ensure you are receiving sufficient hot air output.

The Airo 2 Boost uses 60mm ducting, whereas the Airo 4 uses 90mm for the outlet, and 75mm for the inlet.

Exhaust System

Note: Do not work on the exhaust system unless the heater has been switched off for over an hour and wear safety gloves if necessary. All types of combustion produce high temperatures and toxic fumes and must be installed in accordance to these instructions.

The flexible exhaust pipe can be shortened to no less than 20cm and should not exceed a length of 2m, depending on the installation parameters. Route the exhaust pipe from the heater to a suitable outlet, ensuring that is securely fitted to the heater using the clamp supplied in the kit.

As the exhaust gets very hot during operation, it should be installed in such a way that will not cause damage to the vehicle. So ensure that it has sufficient clearance of heat sensitive parts; paying close attention to fuel lines (plastic and copper) and electrical components. Make sure that the outlet ends in open air and does not point in the direction of travel. The whole system should also point downwards and if necessary, a 5mm hole should be drilled near the bottom to drain off any condensation. You should also route the exhaust so that the fumes are not taken back in by the air intakes of the heater and ensure that the outlet does not get blocked by anything like road debris etc.

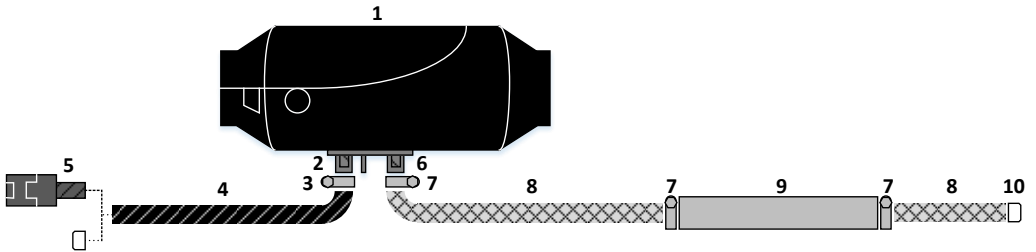

Figure XV

- | | |
|---------------------------------------|------------------------------|
| 1. Heater Body | 2. 25mm Combustion Air Inlet |
| 3. Combustion air inlet clamp | 4. Combustion air pipe |
| 5. Combustion air silencer OR end cap | 6. 24mm Exhaust outlet |
| 7. Exhaust clamp | 8. 24mm Exhaust pipe |
| 9. Exhaust silencer | 10. Exhaust end cap |

Combustion Air Intake

Like the exhaust pipe the combustion air intake can be shortened to up to 20cm or lengthened to no more than 2m, again depending on installation conditions. Some models can also be fitted with a combustion air silencer to reduce the noise of the air intake; this is ultimately down to personal preference.

In some situations, an air filter may be required (not included) to stop dust or debris making its way up the air pipe.



Installation: Fuel Lines

Note: When installing, priming, repairing fuel lines etc. there is always a risk of injuries due to flammable and toxic sources. Take all the necessary safety precautions when fitting any fuel line or fuel line parts.

DO NOT:

- Smoke
- Use naked flames
- Inhale fumes

When working on or near any fuel lines or parts!

DO:

- Ensure the engine and heater are switched off before attempting any and all work on the fuel line installation or repair
- Cut any fuel line with a sharp knife to ensure a clean cut free from crushes and burrs
- Make sure the pipe from the fuel pump to the heater is on a gradual rise
- Ensure fuel pipes are fastened safely to prevent noise rattle and securely fitted to prevent any damage
- Route the fuel pipes so that vehicle vibration and movement will not have any lasting effects on the service life
- Route the fuel line away from **any and all heat sources.** Ensure adequate clearing from heat sources if it cannot be avoided or use a suitable heat shield
- Make sure all connectors are fastened securely to prevent dripping of fuel, particularly onto hot surfaces or electrical components.

Fuel Line Connectors

When connecting fuel pipes into rubber connectors always mount them flush and not on a bend to prevent air bubbles from forming in the fuel line as shown in Figure XV.

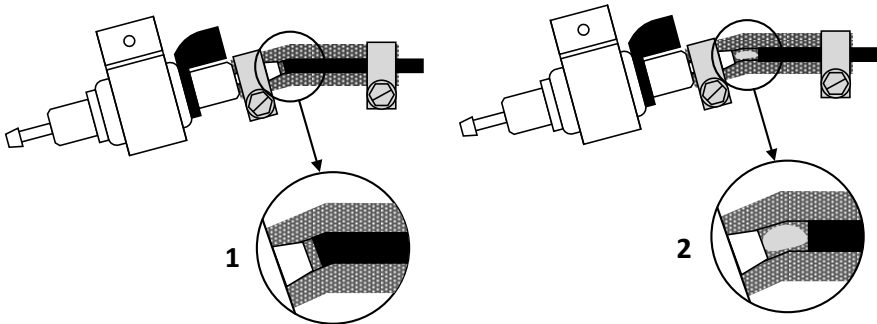

Figure XVI

A fuel filter must be fitted for all diesel heaters. Make sure that it is installed the correct way according to fuel flow as shown in figure XVII.

Note: Fuel filter, pipes and clamps should be replaced after 2 years.

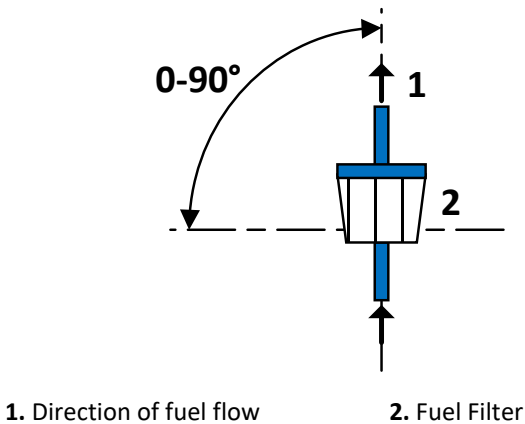

Figure XVII

Fuel Line Length and Order

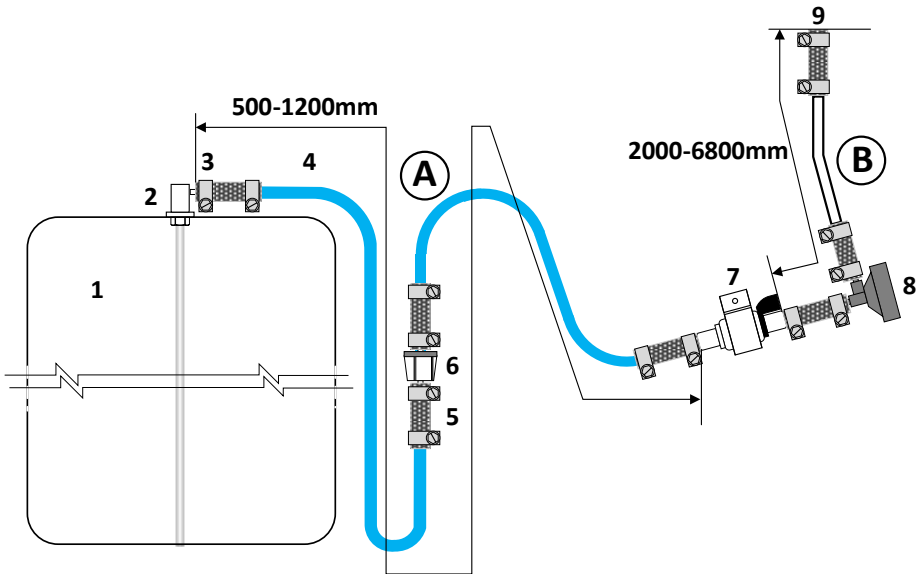

Figure XVIII

- | | |
|--|----------------------|
| 1. Fuel tank | 2. Fuel Standpipe |
| 3. Fuel connector hose clip | 4. Fuel Line |
| 5. Rubber fuel line connector | 6. Fuel Filter |
| 7. Fuel pump with anti-vibration mount | 8. Damper (optional) |
| 9. Heater body | |

A. Blue Plastic Fuel Line

B. Clear plastic Fuel Line

Copper fuel line should be used for inland waterways installations.

Figure XVIII shows how to install parts of the fuel line in the correct order.

Fuel Pump Angle for Installation

Note: Fuel line is best installed straight/upward toward heater at fuel pump end. A damper is only necessary in kits that include one (larger kilowatt heaters).

Always mount the fuel pump with the pressure side rising upward. The preferred position is shown in figure XIX and should be between 15° and 35° .

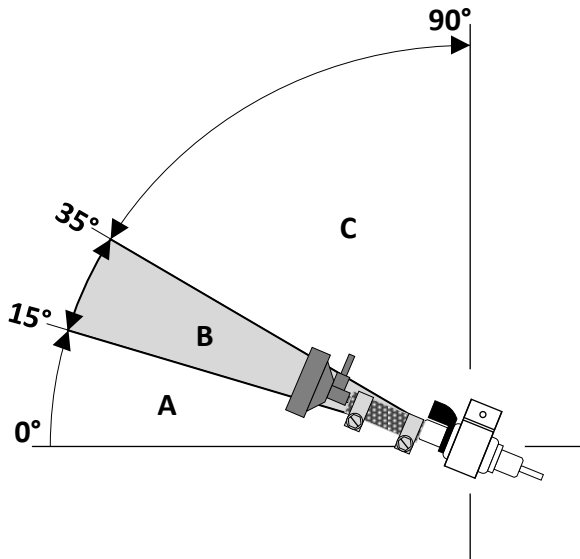
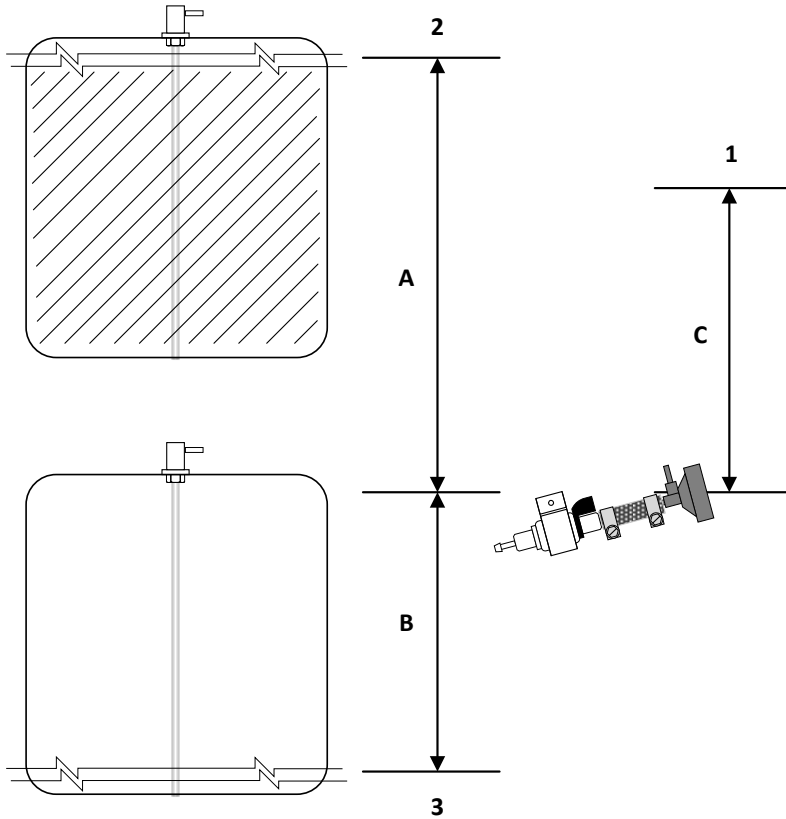

Figure XIX

- A. Between 0° and 15° - Not acceptable
- B. Acceptable installation position: Between 15° and 35°
- C. Between 35° and 90° - Not acceptable

Fuel Tank Head



- 1. Connection to heater body
- 3. Minimum fuel level

- 2. Maximum fuel level

Suction height for fuel pump:

- A. 3000mm
- C. 2000mm

- B. 1000mm (diesel) 500mm (petrol)

Figure XX

Fuel Standpipe

A fuel standpipe (or suction pipe) will need to be installed in the vehicle's fuel tank or an independent fuel tank depending on what the installation calls for. Sealant is not required to fit the standpipes.

Depending on the standpipe provide in the kit you will need to install the standpipe in one of two ways.

Standpipe 1: (**Part No:** AHZ-034)

Figure XXI

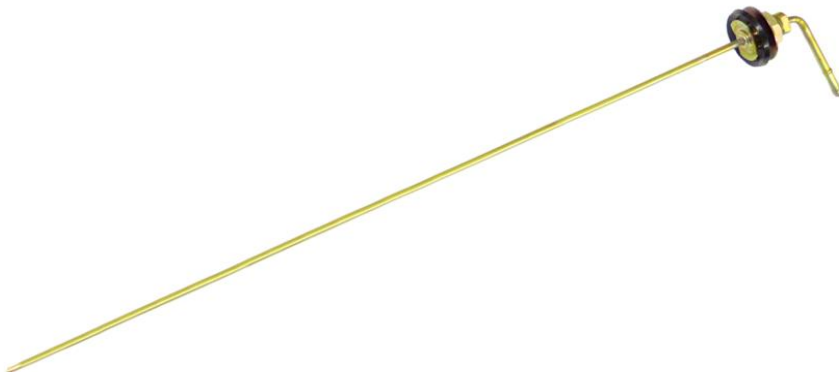

Usually supplied in Marine kits and supplied bent, this standpipe is installed like so:

- Drill a hole in the top of the vehicle's fuel tank $\Phi 22 \pm 0.2\text{mm}$ in size. Ensure it is smooth and clean of burrs
- Remove the top nut and washers and bend the standpipe straight
- Cut the standpipe down to size if necessary
- Fit the standpipe by tilting it into position into the newly drilled hole
- Place the rubber and metal washers back on top followed by the nut and tighten it securely on top

Standpipe 2 (Sender Unit Pipe): (**Part No:** AHZ-035)

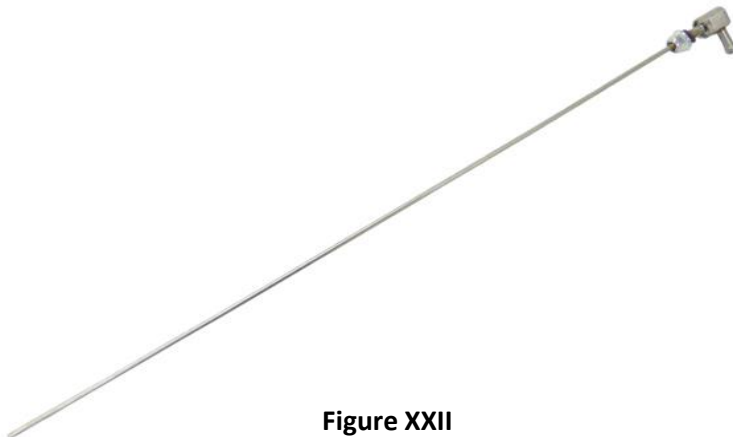

Figure XXII

Supplied mainly in vehicle kits, this standpipe (or sender unit pipe) is installed like so:

- If possible; remove the sender unit from the vehicle's fuel tank, this will make it easier to attach the nut securely back onto the standpipe
- Drill a $\Phi 6 \pm 0.2\text{mm}$ hole into the sender unit
- Remove the nut from the standpipe and feed it through the hole ensuring the rubber 'o' ring remains on the standpipe 'head' side
- Replace the nut on the standpipe to secure it safely to the sender unit.
- Replace the sender unit into the fuel tank.
- To use in a marine application, simply tap an M6 hole into the fuel tank and screw the standpipe inside with the rubber O-ring present.

The bottom of the fuel standpipe should be 30-40mm from the bottom of the fuel tank to allow enough suction of fuel and at the same time not allow impurities and sediment to be drawn up the standpipe.



Electrics: Components

Make sure that all electrical components are arranged in the vehicle so that they function correctly under normal heater operations. Firstly, ensure that no wires are damaged in any way and avoid feeding them through areas that may cause damage to the loom or cause kinking, jamming or exposure to heat. If necessary, fit rubber grommets and plugs around the loom in areas that are not waterproof or may get damaged by road debris. Lastly make sure all connections are free of corrosion and all firmly connected.

Control Switch & Timer

To install the control switch, simply remove the rotary knob (it is quite stiff) and secure in a suitable location with the screw provided, then replace the knob back in the correct location. Alternatively, to fit the mini timer, simply fit the appropriate screw inside the hole located at the center of the timer. Both plug into the corresponding black and clear plugs on the loom.

Note: Only one can be installed at a time.

External Temperature Sensor Probe

The external temperature sensor probe plugs into the corresponding blue and brown wired socket on the diagram and should ideally be mounting at shoulder height when sat down to ensure correct reading of the air temperature. It should not be mounted in such a way as to obstruct air flow; like up high, in the corner of the vehicle cabin or above heat sources.



Wiring Diagram

Figure XXIII

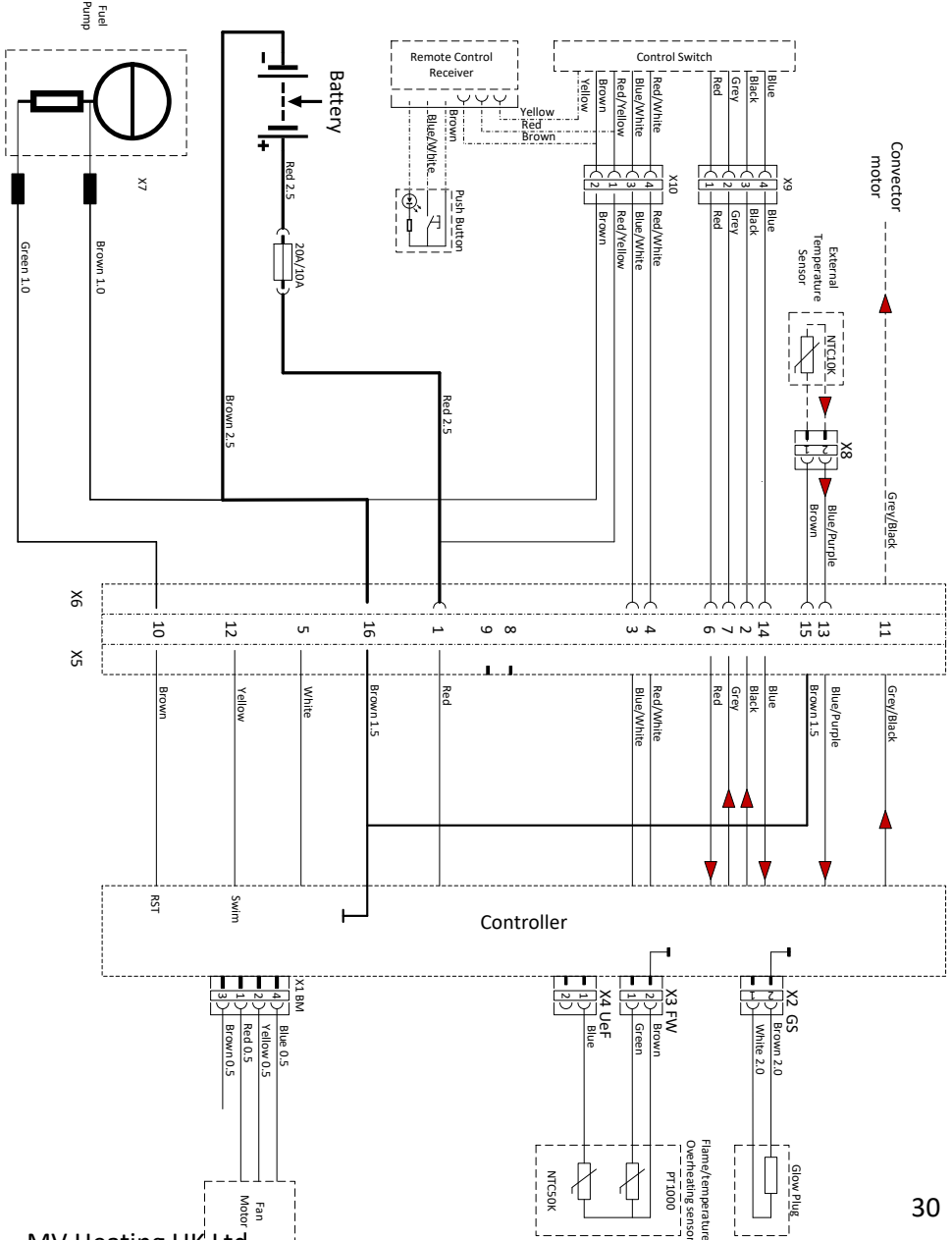

Control Connections

Use a single screw to fix the timer control or rheostat control in place. They are best installed so that they can be seen and operated easily to identify working conditions and also for easy access. The black and clear plugs connect to the corresponding plugs on the loom (below). The remaining three-pin socket on the timer or rheostat control plugs into the remote control receiver if one is installed. An adaptor cable may be necessary.

Timer Control Plug

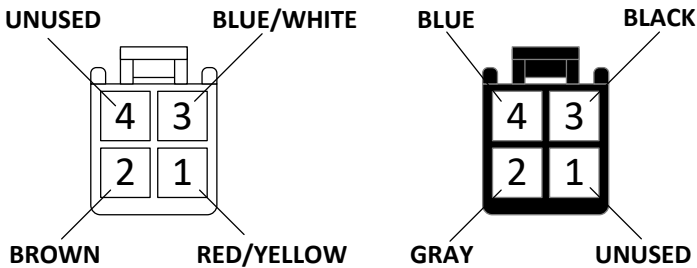

To Timer Control
Figure XXIV

Rheostat Control Plug

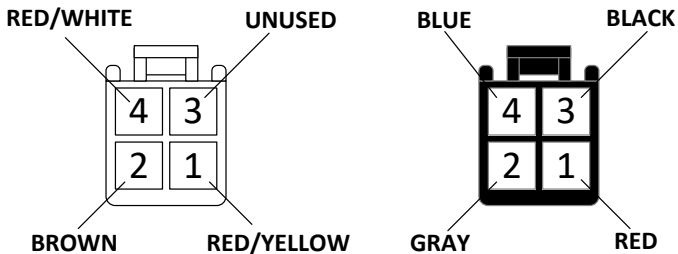

To Rheostat Control
Figure XXV

Wiring Loom Plug for Timer and Rotary Control

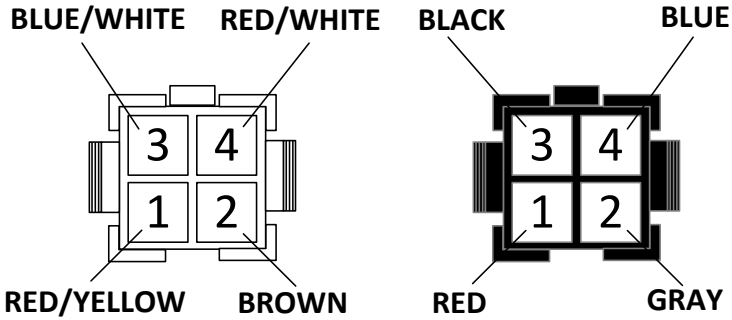

To Main Wiring Harness

Figure XXVI

Any surplus wires should be kept in good condition and wrapped in electric tape to avoid short circuiting.

External Remote Temperature Sensor Probe

The remote temperature sensor probe is best installed at shoulder height whilst sat down, ensuring ample air flow and a clear ambient temperature reading

It is inserted into the corresponding blue and brown wire plug just off from the main E.C.U. connection X6.

ECU Connections

The connections on the E.C.U. are designed in such a way that wrong connections are difficult to make. Excessive force is the only way wrong connections can be made.

The following circuit interfaces can be found on the ECU; these are:

- GS = Glow Pin (White + Brown)
- FW = Overheat and Flame sensor (Green + Brown)
- UeF = Overheat and flame sensor (Blue)
- BM = Air Motor (Red + Yellow + Brown + Blue)

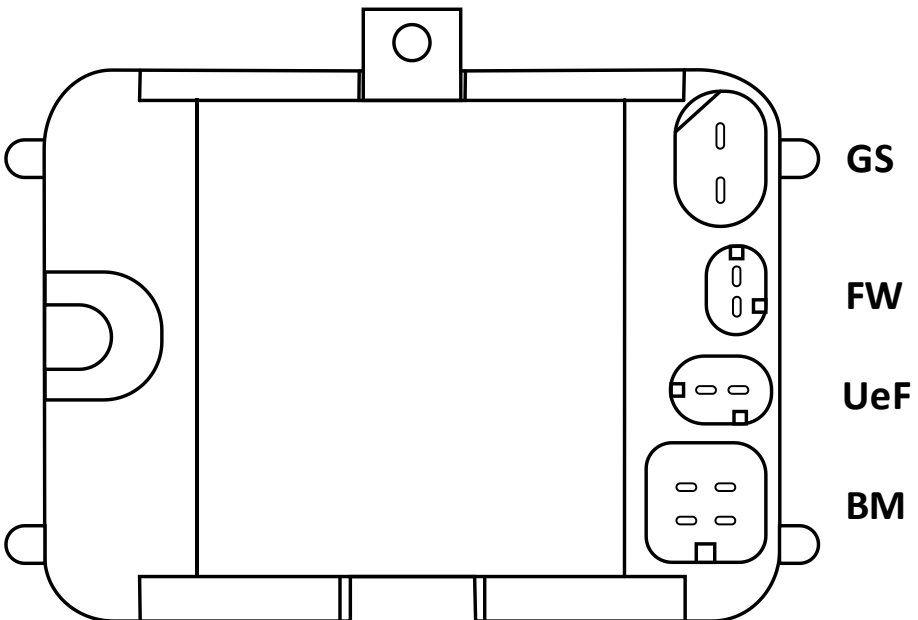

Operation:

Rheostat Control

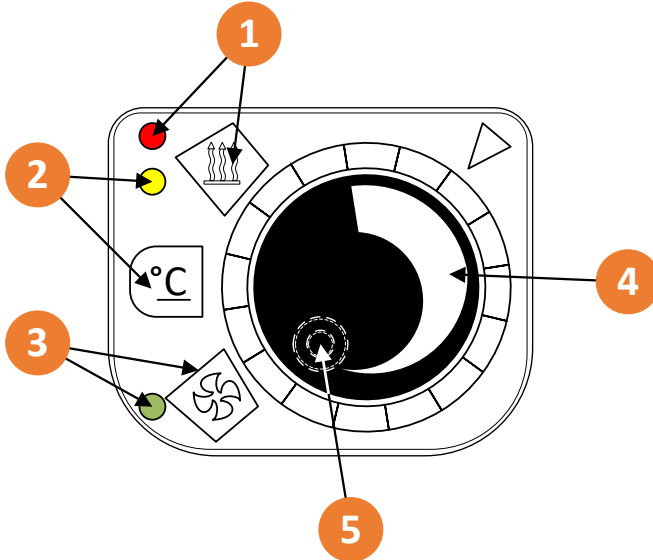

1. Variable Output Button and Indicator Light
2. Temperature Button and Indicator Light
3. Fan Only (Cold Air) Button and Indicator Light
4. Control Knob
5. Fixing Screw Hole (Located underneath control knob)

Figure XXVII

The rheostat (or rotary) control works by twisting the control knob to the desired heat setting, and using the buttons listed to determine the heaters function. Variable output is simply high to low heat. The temperature button switches the heater to thermostatic mode (the heater will then switch to a cool-down cycle automatically once it has reached the selected temperature). The fan button only switches the fan on for cool air.

Operation: LCD Digital 7-Day Timer

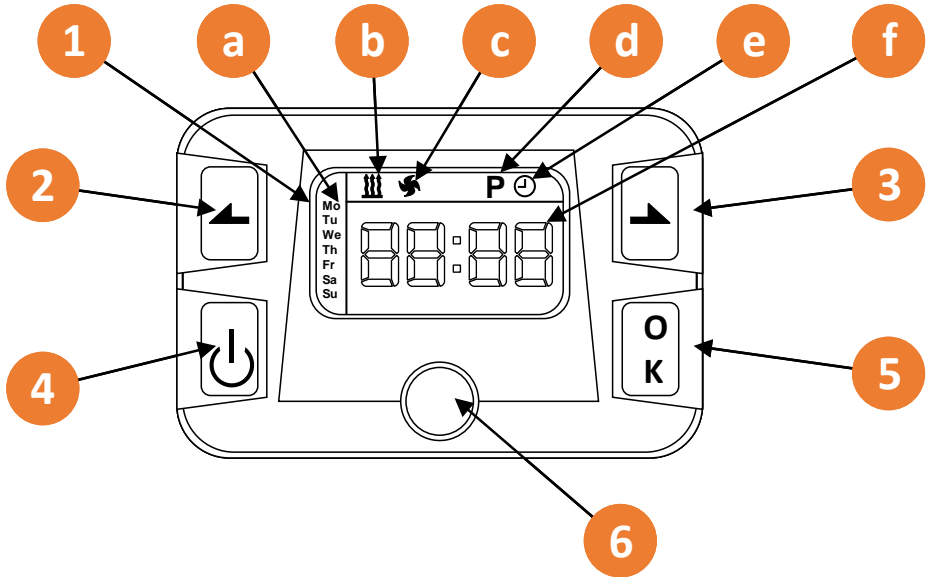

Figure XXVIII

- | | |
|-----------------------|-----------------------------------|
| 1. LCD Screen | a. Days of the week |
| 2. Left Arrow Button | b. Heating Symbol |
| 3. Right Arrow Button | c. Fan Symbol (later models only) |
| 4. Power/Back Button | d. 'P' (Timer) Symbol |
| 5. OK Button | e. Clock Symbol |
| 6. Fixing Screw Hole | f. Clock Face |

Functions:

- 7 day timer, able to be programmed 3 times daily
- 7 step variable output mode
- Thermostatic mode from 05°C to 35°C
- Adjustable cold air fan mode (on later versions)

Changing Language

The language should be set to English. However, if it isn't or the control has been reset to default settings it will revert to Chinese. Please follow these steps to convert the language to English.

1. Turn on the control with the power button. Wait for the symbols to stop flashing, then press the power button again.
2. Navigate to the clock face symbol at the top of the control by using the arrow keys. When it is flashing press both arrow keys simultaneously.
3. P1 now appears.
4. Press ok and C1 will appear.
5. Keep pressing ok slowly until '02:oF' appears.
6. Press any of the arrow keys until the screen reads '02:on'
7. Keep pressing ok until back to the P1 menu screen
8. Press power button to return. The language will now be set to English.

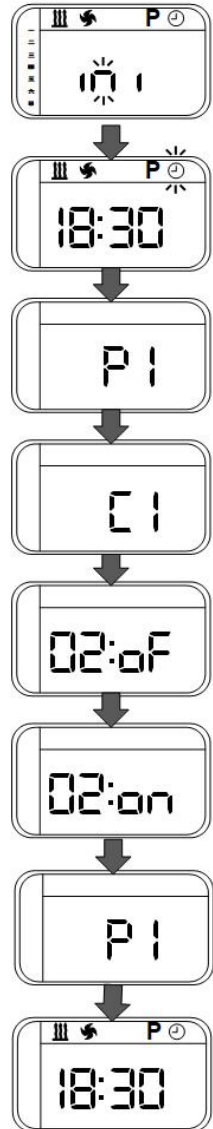

Changing the Date and Time

1. To change the date and time, navigate to the clock face symbol and press ok.
2. Select the day of the week it is first using the arrow keys, and pressing ok to confirm.
3. Select the hour using the arrow keys, and pressing ok to confirm.
4. Finally, select the minutes in the same way.
5. Once completed, the control will return to the home screen (displaying the correct time)

NOTE: If the LCD digital timer is disconnected from the loom, the date and time will need to be re-entered.

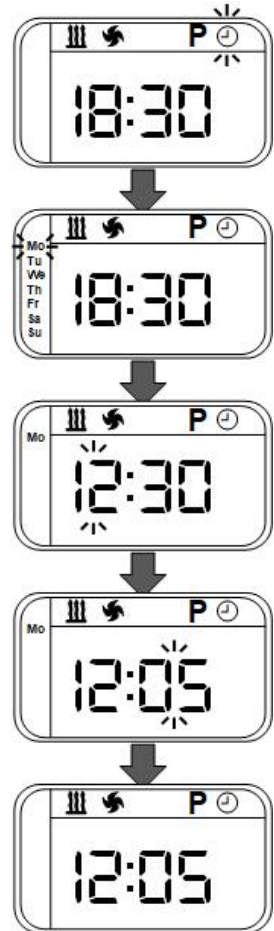

Manual On/Off

1. To switch the power on manually, navigate to the heating icon, and press ok
2. The heater will start automatically.
3. Use the arrow keys to adjust the output of the heater from high to low (07 to 01 respectively)
4. To switch the heater off, simply press the heater button to return to the home screen.

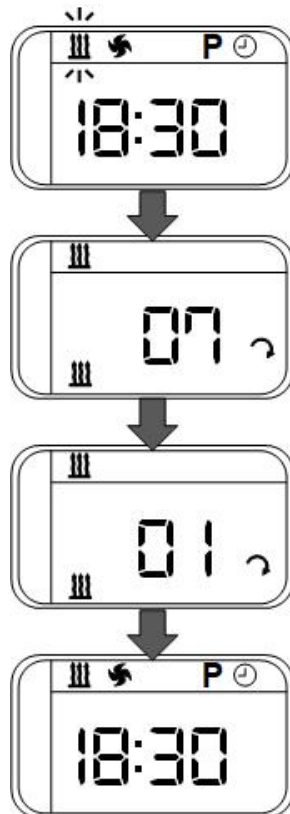

Switching to Thermostatic Mode

To switch to thermostatic mode, turn the heater on manually, as stated in the previous step.

1. Once the heater is on, press and hold the ok button for three seconds and then release it.
2. The display should change to a temperature setting which can be adjusted from 05°C to 35°C using the arrow keys.
3. To adjust back to the variable output mode, simply press and hold the ok button again for 3 seconds and then release it.
4. To switch the heater off, press the power button to return to the home screen.

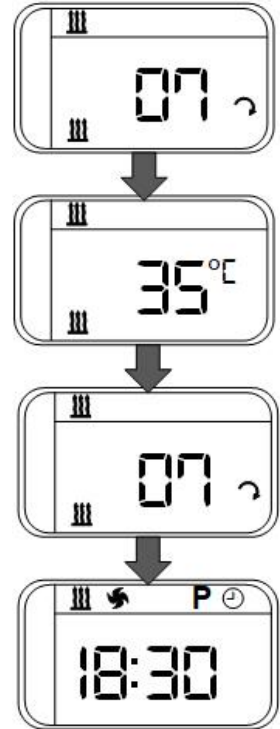

Fan Mode

The fan mode works in the same way as the manual on/off mode. Simply navigate across to the fan symbol and confirm with OK. The fan will then automatically switch on and its speed can be adjusted from high to low (07 to 01 respectively) using the arrow keys. To switch it off, press the power button.

NOTE: Some earlier models will not have this function.

Pre-setting Heating Times

The digital control can be used as a 7-Day timer, and is able to be preset to switch on up to three times a day.

1. Navigate to the 'P' symbol, and press OK.
2. Using the arrow keys select the number 1 (flashing) at the top of the screen and press OK – Number 1 is the first heating time.
3. Using the arrow keys, select 'ON', as this will allow the heater to switch on after the presetting is finished. Press OK to confirm.
4. Select the length of time you want the heater to run for by using the arrow keys. – L800 represents 800 minutes. Run time can be selected from 50-990. Press OK to confirm.
5. Select the hour you wish the heater to start at by using the arrow keys and then pressing OK to confirm.

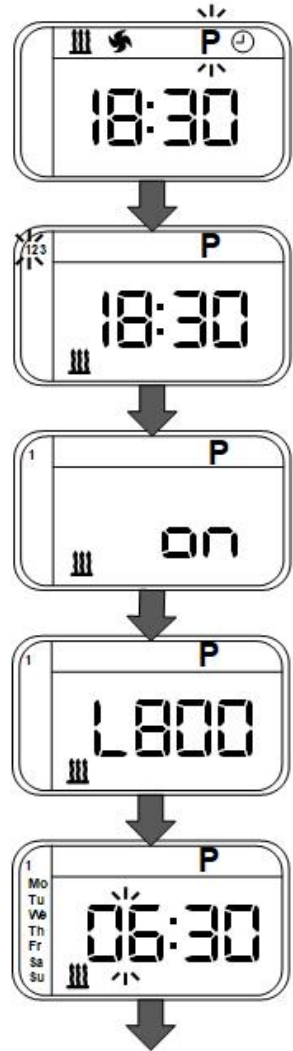

6. Select the minutes in the same way and press OK to confirm.

7. The next step is choosing which day of the week you want the heater to run. Starting with Monday, use the arrow keys to change from 'OFF' to 'ON' and press OK to confirm. Continue this all the way through to Sunday.

8. The preset time should now be set. This will be indicated by the small, underlined number 1 at the top of the screen.

9. To set the second and third heating times, simply repeat all the steps but select 2 or 3 instead of 1 (see step 2.) to set those heating times.

NOTE: To turn any of the preset times off without altering the set times, simply go through to step 3 and select 'OFF' using the arrow keys. Then repeatedly press OK until you have returned to the home screen.

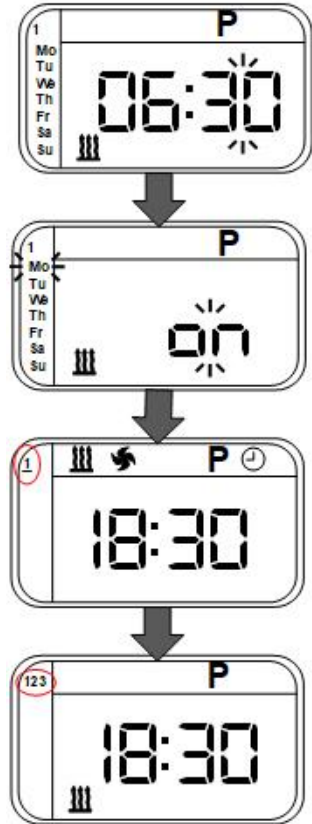

Installation Fuel Priming Feature

ATTENTION:

- Not to be used in normal heater operation
- Disconnect the fuel line from the heater first, to prevent flooding of the heater and place in a suitable receptacle.

1. To enter the fuel priming mode, navigate to the clock face using the arrow keys and press both arrow keys simultaneously.

2. P1 should appear on the screen.

3. Select P2 by pressing any arrow key, and confirm with OK.

4. The fuel pump will begin to rapidly pump the fuel.

5. It will automatically shut down after three minutes, or press any key to stop the pumping at any time, and return to the home screen.

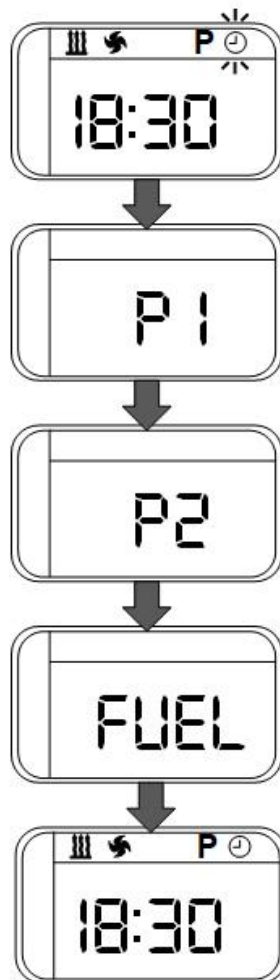

Checking Error Codes

Once an error code has been displayed, and the problem has been amended, follow these steps to reset it.

1. Check the error using the arrow keys. Exit by pressing either OK or the power button.
2. Press both arrow keys to display message 'dEL'.
3. Press OK to delete all errors or power to go back. Once the display reads 'IE00' then no errors have been found.
4. Press OK or power to return.

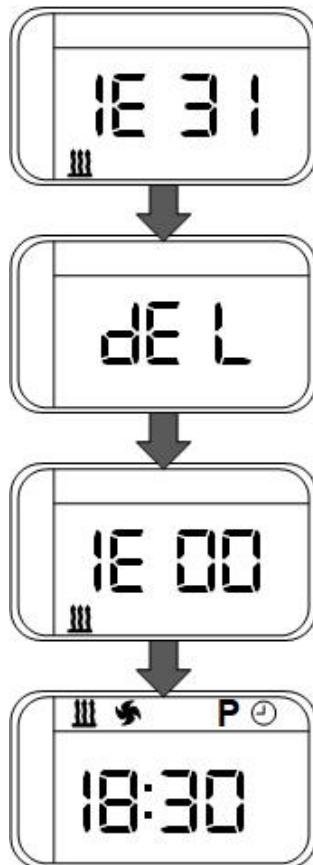

Resetting Digital Controller to Factory Settings

1. Navigate to the clock face on the menu and simultaneously press both arrow buttons.
2. P1 should appear on the screen.
3. Using the left arrow key select '—01', confirm by clicking the 'OK' button.
4. The control should now be reset to its original factory settings.

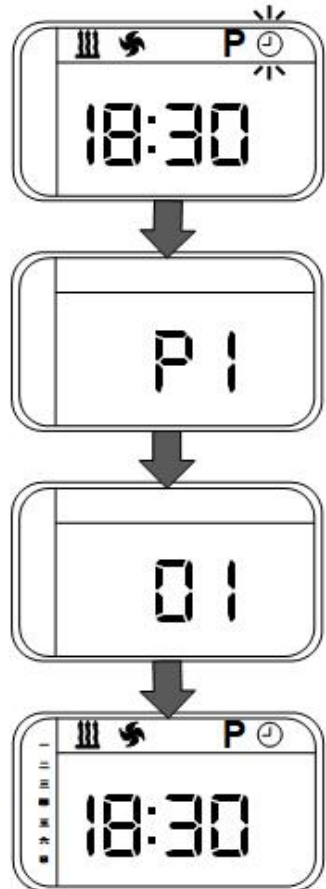

Entering Altitude Mode

1. When the heater is running, press the left arrow key and the 'OK' keys simultaneously. The heating icon, and fan icon should appear at the same time at the bottom of the display. Altitude mode has now been set.

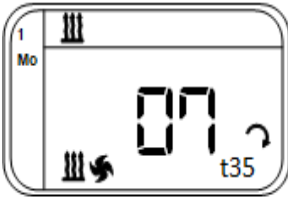

To turn off the altitude mode, press the power button, or press the 'OK' button and left arrow key simultaneously to switch back to the regular heating mode. You can use the arrow keys to change the variable output setting from 01-07.

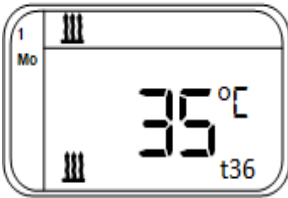

To change the display to thermostatic mode, press and hold the 'OK' button.

Use the arrow keys to change the temperature control.

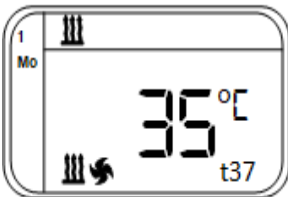

The same can be done whilst in altitude mode. Simply press and hold the 'OK' button to change from variable output, to thermostatic mode and use the arrow keys to change the temperature.

Fault codes can be checked by holding both arrow keys at the same time.



Maintenance

Once the heater is installed, it should ideally be turned on a few times to remove any air trapped in the fuel lines. Also ensure there is no leaking from the lines and that all electric terminals fit securely together.

You should also regularly:

- Check the air inlet and outlet for any pollution or foreign matters
- Clean the externals of the heater
- Check for corrosion or loose connections of the circuits
- Check the combustion air inlet and exhaust pipe for damage and clogs
- Check the fuel line for leaks

To ensure a long life of the heater it is advised that you run it for at least 10 minutes every month, to prevent malfunction of mechanical parts.

After 10 years the heat exchanger, overheat sensor and exhaust should be replaced by a professional.

If any welding is being attempted on the vehicle, please remove the positive power supply wire and earth it to protect the controller from any damage.



Fault Codes:

Rheostat Control

When the ECU had discovered a fault, the rheostat control will flash a fault code. The control should therefore be ideally placed where it can be clearly seen and accessed.

The faults will be displayed as flashes. Count the flashes to determine the code.

Number of Flashes	Cause of Problem
1	Failure of second start
2	Termination of the third time of combustion
3	Voltage power out of specified range
4	Glow plug temperature increases slowly
5	Air heaters will not flash 5 times
6	Temperature sensor: Broken circuit or short-circuit
7	Fuel pump: Broken circuit or short-circuit
8	Fan motor: Broken circuit, short-circuit or clogged
9	Glow pin: Broken circuit or short-circuit
10	Overheated
11	Overheat sensor: Broken circuit or short-circuit
12	Control switch: Broken circuit or short-circuit



Fault Codes: Mini Timer

1E-02 : Overheat – Check for obstruction or damaged ducting

1E-10 : Ignition failure – Check fuel supply, blocked supply or fuel pump

1E-30 : Voltage too high

1E-31 : Voltage too low – check battery or voltage drop in supply cable

1E-52 : Overheat sensor failure

1E-70 : Fuel pump open circuit or ECU failure

1E-80 : Air motor failure

1E-90 : Glow pin failure

1E-d3: Maintenance Reminder

Thank you for purchasing the MV Airo 2 Boost

+44 (0)23 8052 2345

