



MV Combi Heater

MV 4kW AIR & 2kW WATER HEATER

INSTRUCTION MANUAL

Ed 1.00

MV Heating UK Ltd
Unit 6
Second Avenue Business Park
Millbrook
Southampton
SO15 0LP



6kW Combi Heater

The image shows a black and red MV 6kW Combi Heater. It is a compact, rectangular unit with a black top and red bottom. A red gas pipe is connected to the bottom right. There are several warning labels on the front, including a yellow one with a triangle and a red one with a triangle. The unit is shown from a three-quarter perspective.

MV Heating UK LTD
+44 (0)2380 522345



Preface

Thank you for purchasing the MV Combi diesel powered heater. This instruction book describes the structures, working principles, installation and operation of the MV Combi Heater. For correct use of the heater, please read this instruction book carefully before installation and use. The instruction book should be saved in a convenient place for reference later.

Note

- This instruction book is subject to revision without notice, but the instruction book is in conformity to the purchased product.
- Our effort is to explain all questions you may have. If you have any doubts or find anything incorrect in this manual, please contact us directly.
- Check the heater for any damage when unpacking and contact the dealer immediately if anything is found.
- If any troubles arise during application, please contact MV Heating or other customer service stations authorized by this company. We shall do our best to provide service to you.

Disclaimer: Comply with the operation manual for installation and operation, to ensure prolonged and reliable use. The diagrams in this manual do not intend to describe a complete system and should not be taken literally. They are only intended to give an example of how installations can be laid out.



Contents

Introduction	4
Technical data	5
Safety Information	6
Obligations of the Owner/Operator	7
Installation	8
Working Principle.....	9
Pre-Planning.....	10
Installation Positions.....	11
Exhaust and Combustion Air Intake Installation.....	12
Installation of Exhaust Cowl.....	14
Fresh Air In	15
Hot Air Out	15
Water Installation	17
Advice.....	18
Laying Water Lines	19
Installing a 12mm/½” CTS adaptor	20
Non-Return Valve.....	21
Installing a Pressure Relief/Drain Valve	22
Connecting the Water Container	24
Connecting the Cold Water Line	25
Connecting the Hot Water Line	25



Installing a Venting Hose..... 25

Final Checks.....26

Temperature Sensor Probe.....27

Electrical Connections.....28

Warnings!.....28

Connections29

Setting Up the 12V Connection.....30

Connecting the room temperature sensor31

Connecting the Control Unit31

Setting up a 220V connection31

Installation of Fuel Lines32

 Fuel Standpipe35

Operational Precautions37

 220V Overheat Protection37

Final Checks.....38

 Water filling.....38

 Turning off the Heater39

 Drainage of the Heater39

 Maintenance/Repair/Cleaning.....40

Fault Information41

Fault Codes.....42



Introduction

The MV Combi Heater is an integrated air and water heater (hereinafter referred to as the Heater). The heater provides domestic hot water and hot air for heating cabins etc. The heater can use the hot air and hot water function simultaneously, or hot water only if hot water is required.

Note: When the ambient temperature is lower than 3°C, it is recommended that the water tank should be emptied to prevent freezing the water tank.

There are three power options:

Diesel Mode: The heater automatically adjusts the power.

Electrical Mode: Select 900W or 1800W manually according to power supply capability of the vehicle.

Mixed Mode: When the power demand is low (maintaining room temperature for example) the electrical mode is ideal, so the diesel mode will not start until the electrical mode can no longer satisfy the demands. The diesel mode will be switched off first in the power adjustment stage.

In the hot water operation mode, the diesel mode or the electrical mode is used to heat the water tank. The temperature of the water tank can be set to 40°C or 60°C.

In the Diesel mode, the heater works with the lowest power. Stop heating as soon as the set temperature is reached.

Electrical mode: Select the 900W or 1800W heating mode manually according to the power supply capacity of the vehicle



Technical data

MV Combi Heater Technical Data		
Rated Voltage	DC12V	
Operating Range	10.5 ~ 16V	
Short-Term Maximum Power Consumption	8-10A	
Average Power Consumption	1.8 - 4A	
Fuel	Diesel	
Diesel Thermal Power	2000	4000
Diesel Consumption (ml/h)	240	510
Quiescent Current	1mA	
Warm Air Supply (m ³ /h)	287max	
Tank Capacity	10L	
Maximum Water Pump Pressure	2.8bar	
Maximum System Pressure	4.5bar	
Electrical Mode Voltage	~220V	
Electrical Mode Thermal Power	900W	1800W
Electrical Mode Power Consumption	3.9A	7.8A
Working (Environmental) Temperature	-25°C ~+ 80°C	
Operating Altitude	≤1500m	
Weight	15.6KG (anhydrous)	
Dimensions	510x450x300	
Protection Grade	IP21	



Safety Information

Only use the heater with the supplied controls and accessories.

Do not park the vehicle inside a sealed garage or car port with the heater running, as exhaust fumes are toxic. Make sure the heater is turned off fully before leaving the vehicle.

Do not install the exhaust port near an open window, or anywhere where the fumes can be re-circulated inside the vehicle.

Do not store heat sensitive or flammable objects in the same area as the heater, or near any hot air outlets, as these areas will be subject to high temperatures.

Do not store objects in front of any air inlets, or outlets as you can cause the heater to overheat. There must be sufficient room for air to pass through.

Keep the exhaust pipe, cowl and combustion air inlets free from pollutants (i.e. leaves, slush, road debris) and do not touch the area around the exhaust outlet as it will be hot.

Make sure the vehicle is in a well-ventilated area when starting the heater. There may be some smoke on startup, this can be caused by low voltage, or after a long period of not being used.

When cleaning the vehicle, be careful to not spray water into the exhaust outlet.

Do not let children operate the heater.



Obligations of the Owner/Operator

The owner is responsible for the bleeding of the heater and for its maintenance.

The owner must operate the heater correctly.

The fuel system must comply with all legislative regulations.

The owner should check the water pipes regularly for breaks etc. and replace them where necessary.

The owner should drain the water if the heater is not being used to prevent frost damage etc. Warranties will not be covered in the event of frost damage.

MV Heating will not be liable if any modifications are made to the heater or its accessories, or if specifications from this manual are ignored.

Notes on manual: The following information will refer to the exploded diagrams, or figures as (F:P), where 'F' donates the figure, and 'P' donates the number in that figure. For example (2:4) would mean 'Figure 2: Number 4'.

Installation

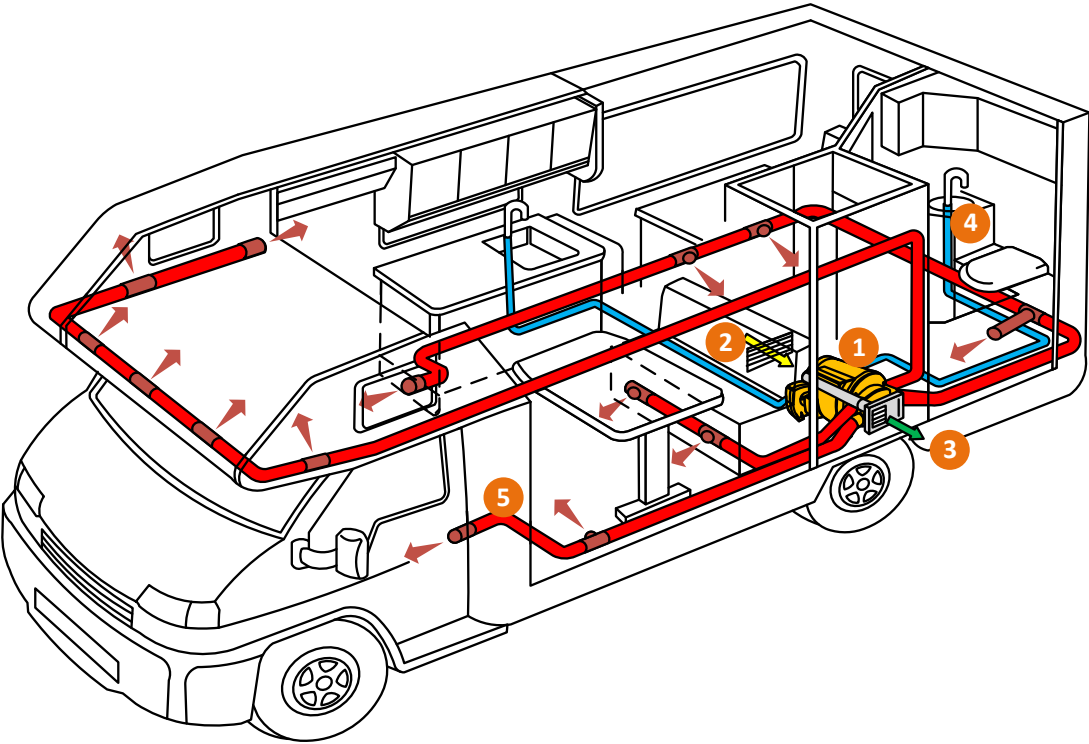

Figure 1

- | | | |
|-----------------------|-----------------------------|-----------------------|
| 1. Heater Body | 2. Fresh Air In | 3. Exhaust Out |
| 4. Water Pipes | 5. Hot Air Out Pipes | |

Figure 1 gives a rough example of how an installation in a motorhome may be prepared. Installation positions will vary depending on vehicle, interior space etc.

Working Principle

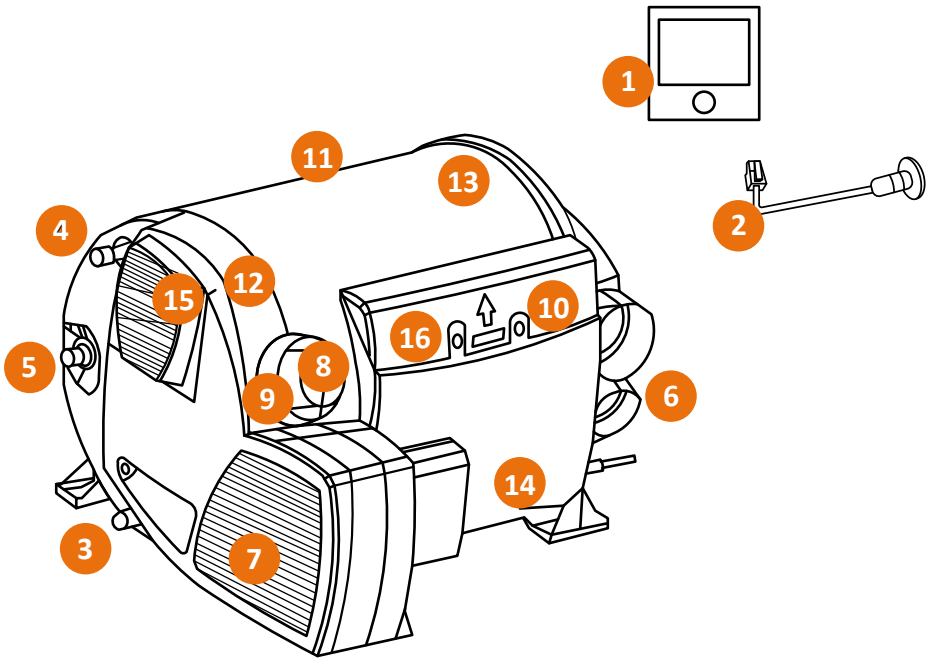

Figure 2

- | | |
|--------------------------------|-------------------------------------|
| 1. Control Switch | 9. Combustion Air Inlet |
| 2. External Temperature Sensor | 10. Main Control Panel |
| 3. Water Inlet | 11. Water Tank (Inside) |
| 4. Hot Water Outlet | 12. Burner (Inside) |
| 5. Fuel Inlet | 13. Heat Exchanger (Inside) |
| 6. Hot Air Outlet | 14. Electrical Control panel |
| 7. Fresh Air Inlet | 15. Electric Warm Air Pipe (Inside) |
| 8. Exhaust Port | 16. Overheat Sensor (Inside) |



Pre-Planning

A suitable installation position should be chosen, that provides the heater with a good load-bearing surface, with plenty of room for ventilation. If a load-bearing surface is not suitable, a bearing surface such as a plywood base should be used.

The heater should be firmly fixed down to the installation surface with screws to prevent any danger or damage to diesel pipes etc. from vehicle movement.

To ensure uniform heat distribution of the heater, the installation position of the heater should be centered as far as possible so that the hot air ducting is as long as possible.

The heater and its exhaust system should be installed with easy access, to allow for servicing and repairs. The distance between the heater and surrounding furniture or vehicle components must be at least 10mm on all sides.

For your safety, a carbon monoxide (CO) alarm should be installed in the vehicle as a precaution, as prolonged or high-level CO inhalation from the exhaust **CAN CAUSE DEATH**. The exhaust outlet must be installed at least 300mm away from any living areas, ventilation openings, or window openings. The exhaust outlet should not be installed beneath a window that can be opened, or near anywhere that the air can be recirculated by the heater.

Installation Positions

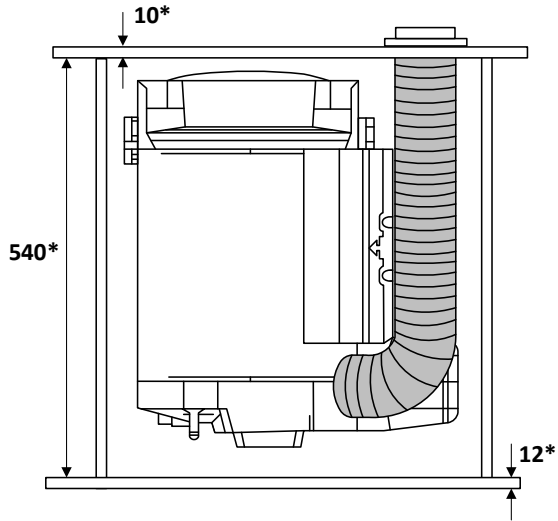

Figure 3

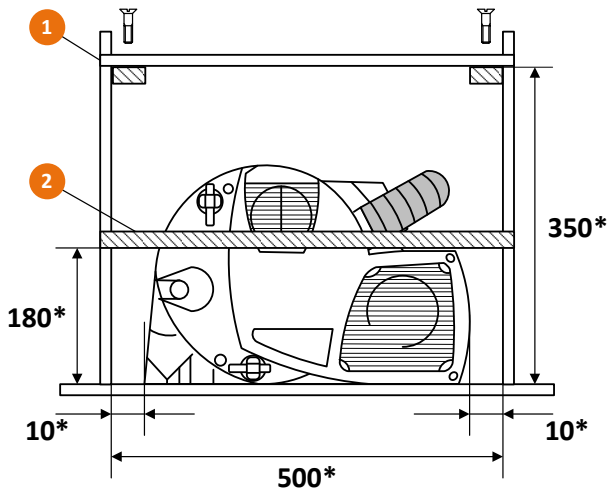

Figure 4

Sizes in **Figures 2 and 3** with a * refer to the minimum size.

Enough space should be left for connecting fuel lines, water pipes etc.

An upper plate (**Figure 3:1**) should be fixed in place to prevent any damage caused by the heater being incorrectly fixed in place. A partition bar (**Figure 3:2**) should be installed in front of the heater, perpendicular to the direction of travel, 180mm above the floor height. Any heat sensitive and/or flammable objects should be kept away from the heater.

Exhaust and Combustion Air Intake Installation

The exhaust and combustion air outlet should ideally be located on the side wall or top plate of the installation compartment. However, it should exit away from any living areas, windows etc. and be a minimum of 300mm away from any ventilation areas and a minimum of 500mm away from the diesel tank, or any associated diesel parts.

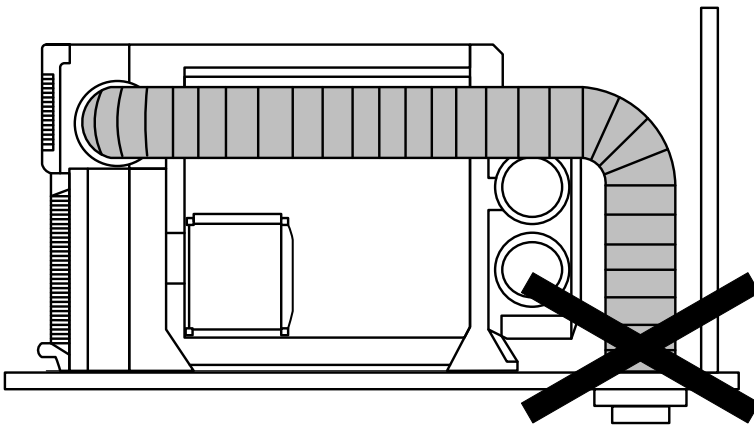

Figure 5

Only use the exhaust and the combustion air intake duct supplied in the kit for the exhaust system. The distance between the exhaust system and any adjacent heat-sensitive parts must be at least 100mm.

The exhaust pipe is inside the combustion air intake pipe. The minimum length of the pipe should be 60cm and the maximum is 200cm.

Ducts with a length of 60-100cm can be routed with any amount of rise to the outlet. But should have a maximum fall of only 20cm. Duct lengths from 100-200cm should only be installed on a rise.

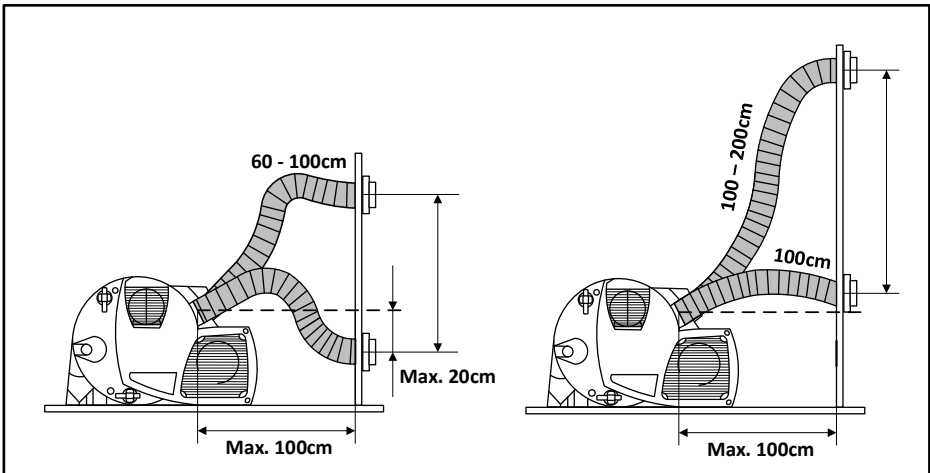

Figure 6

The exhaust outlet must be installed at least 300mm away from any living areas, ventilation openings, or window openings. The exhaust outlet should not be installed beneath a window that can be opened.

Installation of Exhaust Cowl

A flat mounting surface should be selected so that combustion air can enter from all sides. Drill an Φ 83mm hole and use the seal (7:9) with the plane facing the exhaust cowl. Install the fixing clamp before installing the exhaust pipe. Pay attention to the upward mark of the exhaust cowl during installation. The 20mm-long part at the end of the exhaust pipe should be compressed and not straightened. Insert the exhaust pipe into the exhaust outlet (6:8) as deep as possible. Set the fixing clamp up as far as possible and tighten.

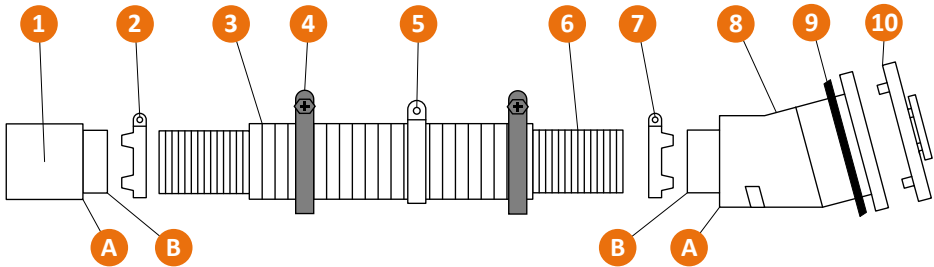

Figure 7

A. Combustion Air Inlet

1. Exhaust and Combustion Air Inlet Port
3. Combustion Air Pipe
5. Plastic P-Clip
7. Fixing Clamp
9. Seal

B. Exhaust Outlet

2. Fixing Clamp
4. Hose Clamp
6. Exhaust Pipe
8. Exhaust Outlet
10. Exhaust Cowl

Attach the exhaust pipe (7:6) to the exhaust outlet (7:8) and inlet port (7:1), and secure with the toothed hose clamp (7:7). Fit the seal (7:9) over the outlet and use six screws to fix the outlet in place, and two to fix the cowl (7:10) onto the outlet. Slide the larger combustion air intake pipe (7:3) over the inlet and outlets and secure with hose clamps (7:4). The intake and exhaust pipes can be fixed to the side wall with the plastic p-clips (7:4).

Fresh Air In

The circulated air is drawn in by the heater. This must have one large or several small openings with a total area of at least 150cm² between the living area and the installation compartment to successfully draw in air (**Figure 4**) and prevent the unit from overheating.

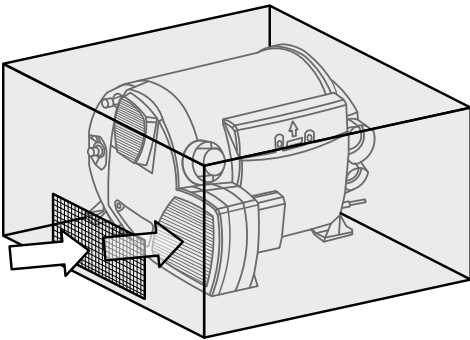

Figure 8

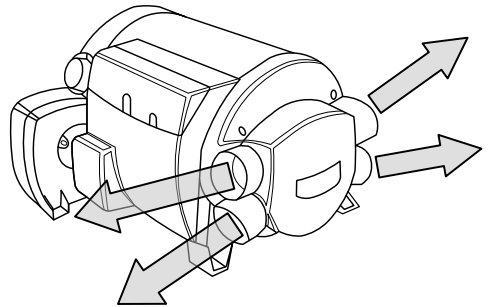

Figure 9

Hot Air Out

Most of the warm air is fed into living area via flexible ducting. The 4 connections on the unit (**Figure 8**) are designed for 60mm ID diameter APK ducting (65mm OD). If there is a lack of space and the warm air ducting must be bent directly behind the warm air outlet of the heater, a 90° elbow may be used between the warm air outlet and the warm air ducting.

If the length of the hot air ducting is less than 2 meters, the hot air outlet should be installed on the same plain as the hot air connector itself. If the length between the hot air outlet connector, and the hot air outlet is less than 50cm, then a bend should be installed in the ducting (**Figure 6**) to prevent unwanted convection heating in the installation area during hotter months.

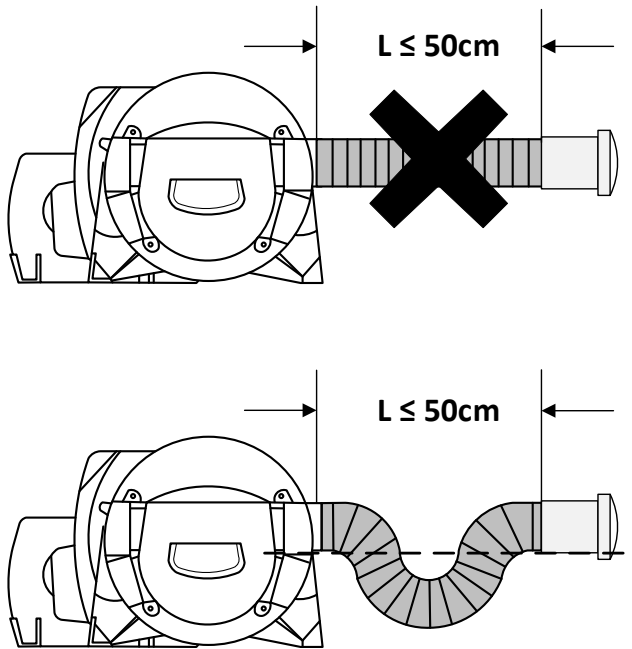

Figure 10

- Make sure the hot air ducting is firmly inserted into the hot air connector and secured with a hose clip.
- Ensure that all four hot air outlets are connected to maximise heat distribution.
- The ducting should not be reduced or obstructed in anyway.

Water Installation

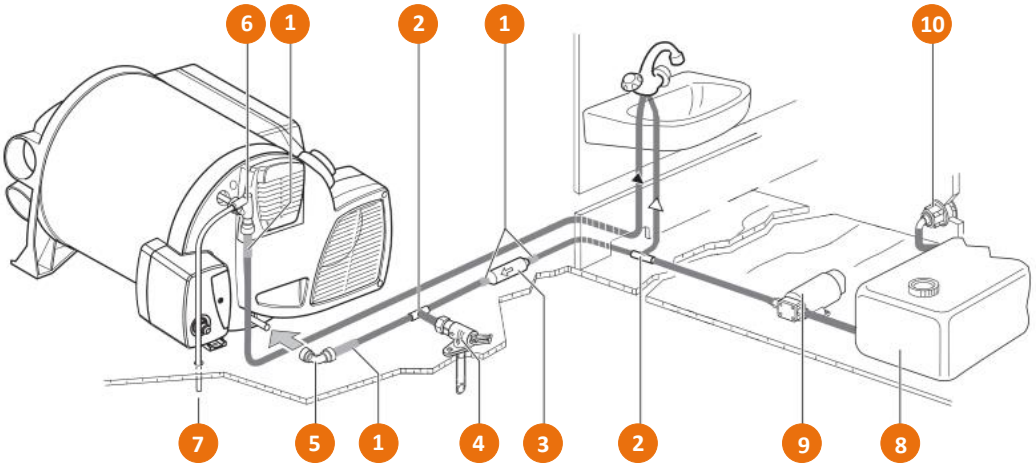

Figure 11

- 1.** Adaptor 12 mm to ½" CTS tube
- 2.** T-Piece (not included)
- 3.** Non-Return Valve (not included)
- 4.** Pressure Relief/Drain Valve (not included)
- 5.** Cold Water Connection
Elbow fitting – push-fit 12 mm
- 6.** Hot Water Connection
Elbow fitting (with aeration valve) – push-fit 12mm
- 7.** Venting Hose, external diameter 11mm
- 8.** Fresh Water Tank
- 9.** Water Pump (not included)
- 10.** Water Connection to the Fresh Water Tank



Advice

- A professional installer with practical experience making connections using push-fit systems is recommended
- Regarding heater operation, pressure pumps and submersible pumps operating at pressures as high as 40.6 psi (2.8 bar) as well as hot/cold mixing taps with or without an electrical switch can be installed.
- Pressure regulators or similar devices are advised to protect the Combi container, in a situation where overpressure can occur - Above 40.6 psi (2.8bar).
- During heating, the thermal expansion of water can result in pressures as high as 65.25 psi (4.5 bar) before the pressure relief/drain valve responds.
- All water lines connected to the heater must withstand temperatures in excess of 80 °C. They must also be suitable for potable water and must withstand pressures as high as 65.25 psi (4.5 bar).
- A non-return valve (**11:3**) should be placed between the first branch and a submersible pump if a pump is being used.
- If you use pressure pumps that exhibit considerable switching hysteresis, hot water can flow back via the cold water tap. You must install a non-return valve (**11:3**) between the outlet to the cold water tap and the pressure relief/drain valve to prevent backflow. Install the water lines so as to ensure that all connected components function as



intended. More specifically, water lines must be as short, kink-free, and unstressed as possible.

- Lay cold water lines higher than the pressure relief/drain valve. **Non-compliance will void warranty claims for frost damage.**
- All water lines should have a minimum clearance of 25mm between any heat sources.
- To avoid the risk of frost damage, the heater's cold-water supply must not come into contact with cold bridges such as the vehicle's side wall.
- An adaptor must be installed at every junction between a 12 mm push-fit system and a 1/2 in. CTS tube.
- All hose connections, even cold water, must be secured with hose clips and/or clamps.

Laying Water Lines

- Connect built-in components of the water system to the water lines; see example diagram, figure 11.
- Regarding 1/2" CTS water lines for connections to 12mm push-fit system: Install an adaptor; see figure 12

Installing a 12mm/½" CTS adaptor

An adaptor must be installed at every junction between a 12mm push fit system and a ½" CTS tube.

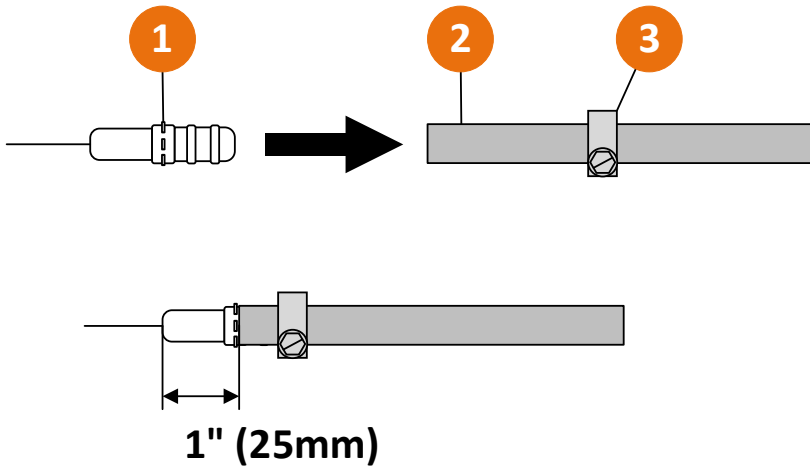

Figure 12

- 1.** 12mm to ½" CTS tube Adaptor
- 2.** ½" CTS tube
- 3.** Hose Clamp

Non-Return Valve

Installing a non-return valve (not included) between the outlet to the cold water tap and the pressure relief/drain valve will prevent hot water from flowing back via the cold-water tap.

- Install the non-return valve in the cold-water line.
- Insert the non-return valve in the proper direction.

Figure 13 shows an example of a non-return valve, with arrow pertaining to direction of water flow

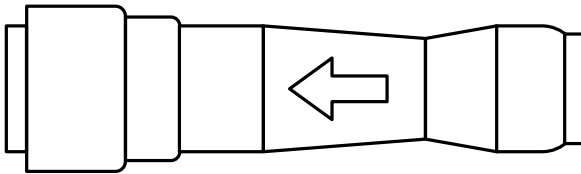

Figure 13



Installing a Pressure Relief/Drain Valve

The Combi furnace with indirect supplementary water heating must be installed with a pressure relief/drain valve (Figure 14) that complies with the standard for Relief Valves for Hot Water Supply Systems, ANSI Z21.22 / CSA 4.4. We recommend installing a pressure relief/drain valve (65.25 psi (4.5 bar) – not included in scope of supply).

- The pressure relief/drain valve must be accessible for servicing or replacement.
- The drain and test lever (**14:2**) must likewise be accessible.
- Install the pressure relief/drain valve in the cold-water line – between the non-return valve and the Combi furnace.
 1. Drill a hole in the floor.
 2. Slide the hose (**14:4**) onto the drainage socket (**14:3**).
 3. Install the drainage hose (**14:3**) in a straight line to outdoors, where it must terminate in a splash-proof position. Install a splash guard, if necessary.
 4. Use 2 screws (**14:3**) to secure the pressure relief/drain valve

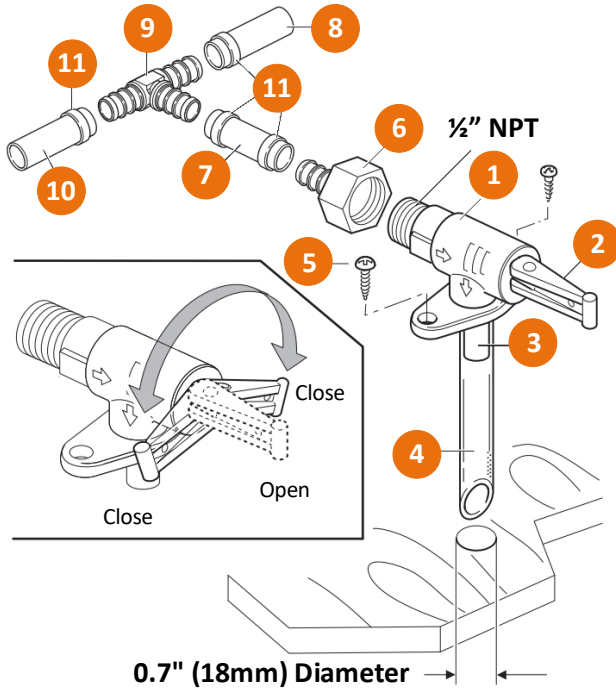

Figure 14

1. Pressure relief/drain valve
2. Drain and test lever
3. Drainage socket
4. Drainage hose
5. Screws B 5.5 x 25 mm (2 screws)
6. 1/2 in. PEX x 1/2 in. NPT female threaded adapter
7. 1/2 in. CTS PEX tube
8. Cold water line inlet 1/2 in. CTS PEX tube
9. 1/2 in. x 1/2 in. x 1/2 in. PEX tee
10. Cold water line outlet 1/2 in. CTS PEX tube
11. Crimp ring or clamp

Connecting the Water Container

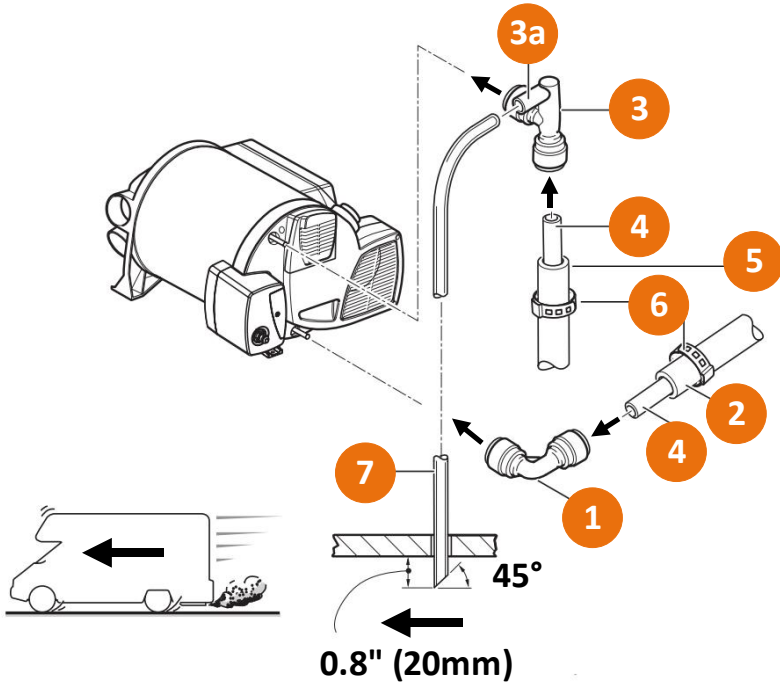

Figure 15

1. Cold water connection elbow fitting (push-fit 12mm: blue)
2. Cold water line – ½" CTS
3. Hot water connection elbow fitting (with aeration valve; push-fit 12 mm: red)
- 3a. Aeration valve hose nozzle
4. 12mm to ½" CTS adaptor
5. Hot water line – ½" CTS
6. Hose clamp (not included in scope of supply)
7. Venting hose, external diameter 7/16" (11mm)



Connecting the Cold Water Line

1. Insert the prepared ½” CTS cold water line with adaptor (15:2) into the elbow fitting (15:1) until it fits snugly.
2. Insert the elbow fitting (15:1) into the lower connection (cold water supply) of the water container until it fits snugly.

Connecting the Hot Water Line

1. Insert the prepared 1/2 in. CTS hot water line with adaptor (15:5) into the elbow fitting (15:3) until it fits snugly.
2. Insert the elbow fitting (15:3) into the upper connection (hot water outlet) of the water container until it fits snugly.

Installing a Venting Hose

1. Drill a hole (Ø 7/16” (11mm)) in the Motorhome’s undercarriage.
2. Slide the venting hose (15:7) onto the hose nozzle of the aeration valve (15:3a).
3. Angle the venting hose (15:7) downward, ensuring there are no kinks.
– Minimum radius of curve: 1 1/2” (40mm).
4. Make sure that the venting hose extends only 0.8” (20mm) beneath the motorhome’s undercarriage. Cut the end of the hose at a 45-degree angle (Figure 15).



Final Checks

- Pull on all the water connections to ensure that they are securely connected.
- Check all water connections for leaks.
 - Repair leaks as needed.
 - Repeat check for leaks and take any necessary steps to repair the leaks at all water connections

Temperature Sensor Probe

Note: The room temperature sensor probe must be connected, otherwise the Combi heater will malfunction.

We recommend installing the temperature sensor in the following way to maintain a steady room temperature:

- Do not subject it to direct heat.
- Install it above the main door.
- Install it on a vertical wall. The room temperature sensor must be completely exposed to the ambient air.

1. Drill a hole.
2. Feed the end of the cable with the one insulated connector through the drill hole.
3. Connect the cable to the sensor, regardless which side, as polarity is not an issue.
4. Insert the room temperature sensor. Run the end of the cable with the plug to the Combi heater.

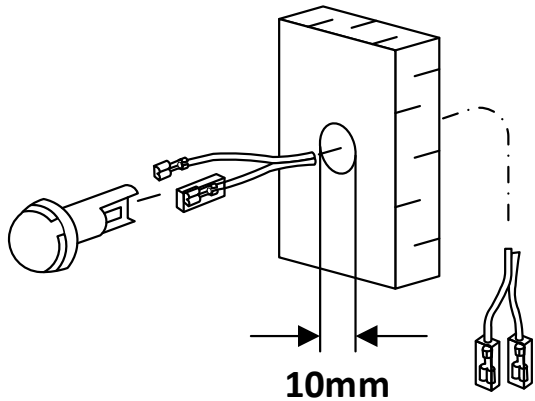

Figure 16

If necessary, the connector cable can be extended using cables (2 x AWG 20 (2 x 0.5 mm²)). However, the overall length must not exceed 33ft (10m).



Electrical Connections

Warnings!

Hazard due to electrical current

- The heater must be electrically grounded.
- Improper installation can cause property damage, injury or loss of life.
- Installation should be installed by a professional
- Always turn the power supply off when work is being carried out and all lines disconnected.

Fire hazard and risk of short circuit due to unsuitable or improperly installed connector cables!

- Due to temperatures in excess of 105 °C, never attach or run connector cables near
 - metal surfaces of equipment,
 - aluminium frame feet
 - exhaust tubes, or
 - warm air ducts.
- Install connector cables in a way that they cannot fray. In the case of sharp edges like drill holes use grommets, bushings or edge protectors.
- All lines that extend outside the vehicle must be splash-proof at the vehicle's side wall.
- Use the specified cable cross-sections only.
- Never connect additional electrical components to the connector cables.
- Connector cables and lines must be securely fastened; they must not become loose or be disconnected due to vibration.
- Electric lines, switching equipment, and control units for the Combi heater must be arranged in such a way in the vehicle that they will function flawlessly under normal operating conditions.

Connections

Electrical connections are underneath the heater's connection cover (17:1). While detaching or reattaching the connection cover, take care to neither dislodge nor pinch the connector cables.

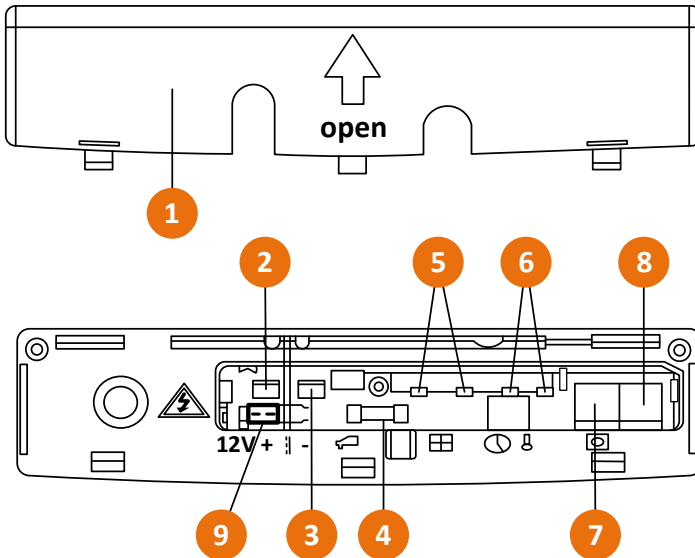

Figure 17

1. Connection cover
2. Input voltage + 12V
3. Input Voltage Ground
4. Main Fuse (20A)
5. Wire Bridge
6. Temperature Probe
- 7 & 8. Control Switch
9. Fuel Pump

Remove the connection cover by simultaneously depressing and sliding it as indicated by the arrow.

All electrical connections to the heater must consist of sagging connector cables. This will prevent condensation from water seeping into the furnace via the connector cables.

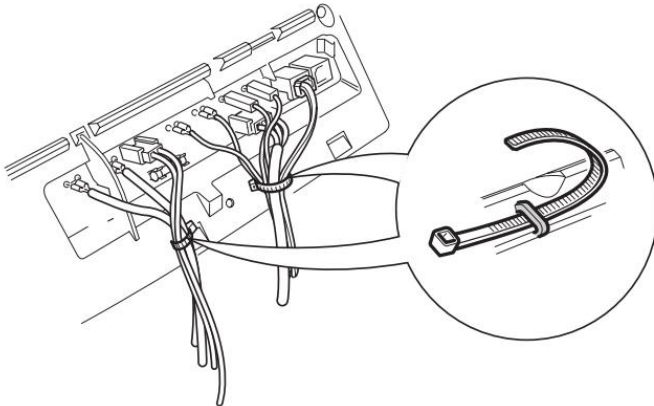

Figure 18

The cables should not be subject to any strain. Use cable ties to bundle wires and secure them to the housing to provide strain relief. As per figure 18.

Cables should exit out of the two cutaways on the connection cover (figure 17).

Setting Up the 12V Connection

The Heater has reverse polarity protection. If the controller is not connected with the correct polarity, the LED indicator will not work. To ensure the best power supply, the Heater must be connected to the on-board power supply (or battery) protected by fuse (10A) with 2×2.5mm² cable (2×4mm² if the length exceeds 6m).



Drops in voltage in the supply line must be taken into consideration.

- Connect the negative wire to the central ground. If connected directly to the battery, the positive wire and the negative wire must be fuse-protected.
- DO NOT connect any other load to the 12V connection

Connecting the room temperature sensor

Insert the connector cable into the connection (17:6). Polarity is not a concern.

Connecting the Control Unit

Fully insert the connector cable into the connection. (17:7&8)

Setting up a 220V connection

WARNING: Hazard due to electrical current! Improper installation can cause property damage, personal injury, or loss of life. Installation must be performed by a licensed electrician to regulation standards.

Use a type G standard plug (not included) to connect the heater to the power supply. Ensure it is connected with a 20A fuse, and properly grounded.

230V lines must be kept completely separate from 12V lines. Secure all lines with clamps.

Installation of Fuel Lines

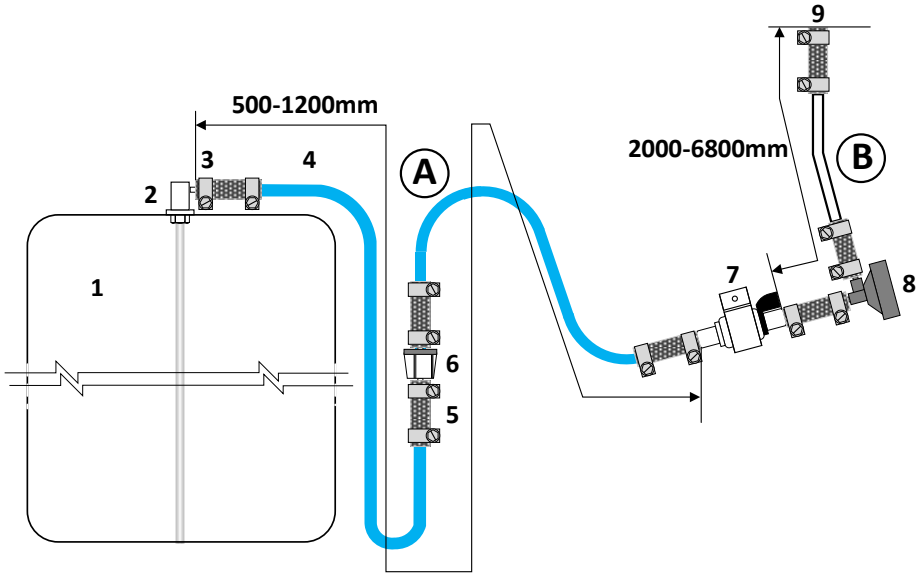

Figure 16

- | | | |
|---------------------------|----------------------------|----------------------------------|
| 1. Fuel Tank | 2. Fuel Standpipe | 3. Fuel line connector hose clip |
| 4. Fuel Line | 5. Fuel line connector | 6. Fuel Filter |
| 7. Fuel Pump | 8. Damper | 9. Heater Body |
| A. Blue Plastic Fuel Line | B. Clear Plastic Fuel Line | |

NOTE: Copper fuel should be used for inland waterways vessels.

The vehicle's own fuel tank can be used to supply fuel to the heater, a separate tank can be used if necessary. If a separate tank has been used, please ensure that it is not installed in the driver or passenger cab and is away from anything that could cause a fire risk or inhaling of toxic fumes.

Always fit the fuel pump on the anti-vibration mount securely onto the vehicle. Ensure the outlet of the fuel pump tilts upward. The correct angle is shown in figure 17.

Where possible the fuel line should ideally be placed uphill to the fuel pump to ensure ideal bleeding of the fuel line.

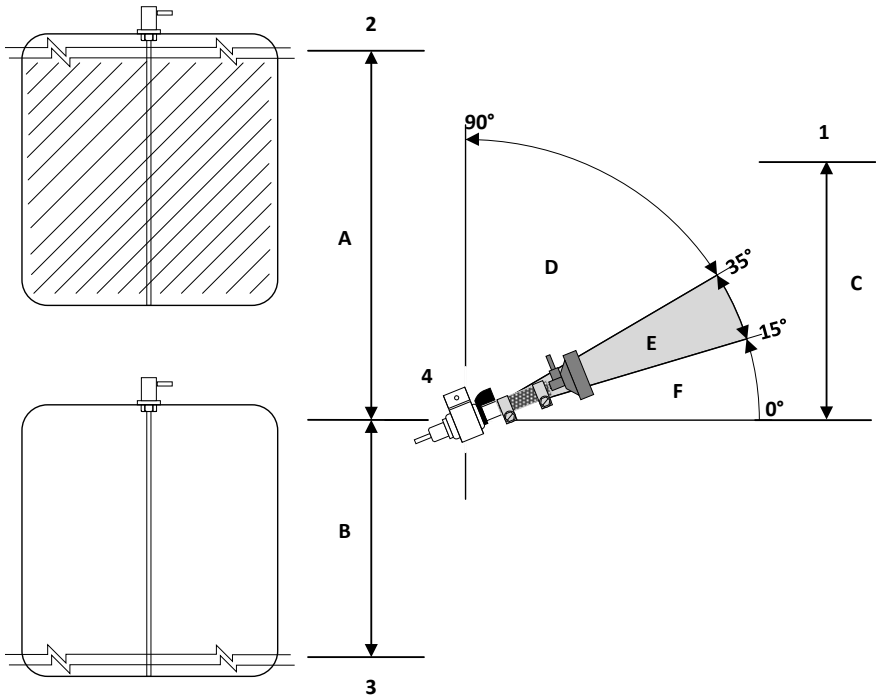

- 1. Heater Body
- 3. Min. Fuel Level

- 2. Max. Fuel Level
- 4. Fuel Pump and Damper

Fuel Pump Angle & Suction Height

- A. 3000mm
- C. 2000m
- E. Acceptable (between 15-35°)
- B. 500mm
- D. Not acceptable
- F. Not acceptable

Figure 17

Figure XVIII shows the ideal angle to mount the fuel pump

The fuel pump's outlet should tilt upward at an angle between 15°-35° (as shown above). Only use the fuel line provided, ensure the pipe is placed away from any possible debris and avoid any sagging in the line. Make sure the fuel line does not flow downward toward the fuel pump. This will prevent correct fuel flow and produce air bubbles in the line.

The fuel filter, fuel pipe and clamps should all be replaced after 2 years of us

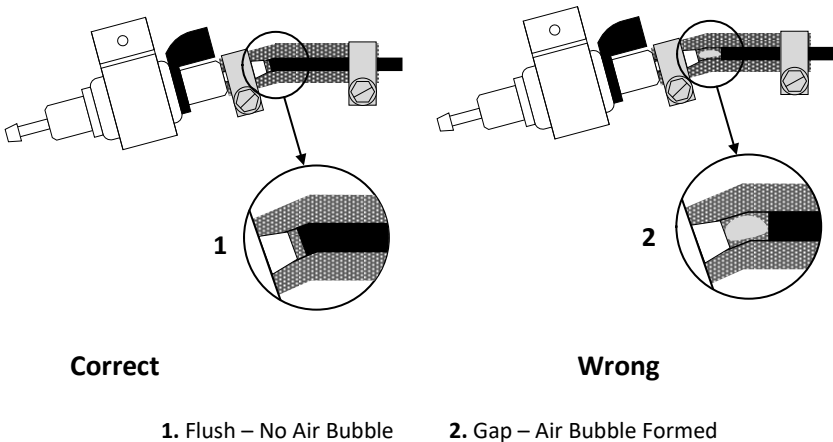

Figure 18

Figure XIX shows the correct way to connect fuel lines to prevent the build-up of air bubbles. Ensuring they are flush and minimising bends.

When the fuel is being sucked from the vehicle tank, or an independent tank, a suction pipe is required. Make sure all the openings are appropriate for the installation and a tight seal is maintained for the base of the suction pipe.

The bottom of the suction pipe should be about 30-40mm from the bottom of the fuel tank so as to avoid sucking impurities or sediment from the bottom of the fuel tank.

Fuel Standpipe

A fuel standpipe (or suction pipe) will need to be installed in the vehicle's fuel tank or an independent fuel tank depending on what the installation calls for. Sealant is not required to fit the standpipes.

Depending on the standpipe provide in the kit you will need to install the standpipe in one of two ways.

Standpipe 1: (**Part No:** AHZ-034)

Figure 19

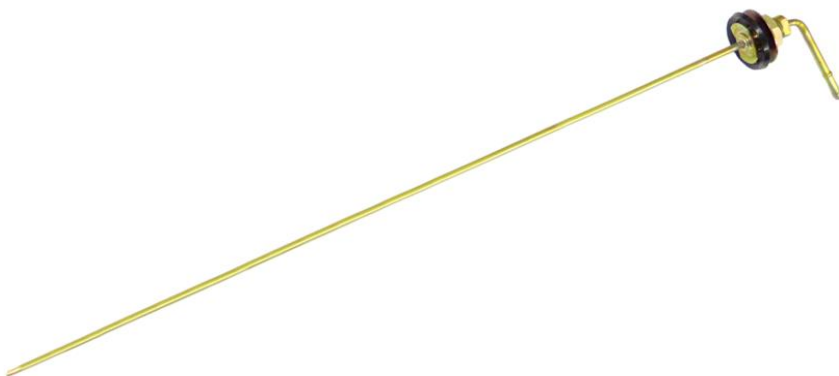

Usually supplied in Marine kits and supplied bent, this standpipe is installed like so:

- Drill a hole in the top of the vehicle's fuel tank $\Phi 22 \pm 0.2\text{mm}$ in size. Ensure it is smooth and clean of burrs
- Remove the top nut and washers and bend the standpipe straight
- Cut the standpipe down to size if necessary
- Fit the standpipe by tilting it into position into the newly drilled hole
- Place the rubber and metal washers back on top followed by the nut and tighten it securely on top

Standpipe 2 (Sender Unit Pipe): (**Part No:** AHZ-035)



Figure 20

Supplied mainly in vehicle kits, this standpipe (or sender unit pipe) is installed like so:

- If possible; remove the sender unit from the vehicle's fuel tank, this will make it easier to attach the nut securely back onto the standpipe
- Drill a $\Phi 6 \pm 0.2\text{mm}$ hole into the sender unit
- Remove the nut from the standpipe and feed it through the hole ensuring the rubber 'o' ring remains on the standpipe 'head' side
- Replace the nut on the standpipe to secure it safely to the sender unit.
- Replace the sender unit into the fuel tank.
- Alternatively, to use in a marine application, simply tap an M6 hole into the fuel tank, and screw the fuel standpipe with O-ring inside.

The bottom of the fuel standpipe should be 30-40mm from the bottom of the fuel tank to allow enough suction of fuel and at the same time not allow impurities and sediment to be drawn up the standpipe.



Operational Precautions

- Do not operate the heater during refueling., or in confined spaces such as closed car parks, garages, or ferry cabins.
- Regularly check the condition of air intakes and exhaust pipe to ensure they are not blocked, reliably fixed, and in good condition (not damaged).
- If black smoke occurs check that all inlets and outlets are unobstructed and free from blockages. If problem persists, the unit may need to be serviced by an authorized professional.
- Regularly check all hot air outlets are unobstructed to avoid overheating. The overheat switch will immediately cut the fuel supply.
- The Heater shall be equipped with a safety cut-off device to meet the heating needs during driving. If there is no safety cut-off device, the Heater must be turned off before driving.
- Only identical T20A fuse should be used as a replacement.
- Fuses and wire harnesses must be replaced by authorized professionals.
- All power must be disconnected before opening the control panel or attempting any work on the heater.

220V Overheat Protection

The electrical heating function has a mechanical overheat protection switch. If the 12V power supply is interrupted during or after the heating process, the radiating heat of the Heater will trigger the overheat protection switch.



Final Checks

Operate the heater with the LCD switch (see separate operation manual).

The main machine heating by diesel, electrical, mixed mode, heated water tank or unheated water is set as required.

Check the power supply capacity of electrical in motor home camp and select electrical mode 900W(3.9A) or 1800W(7.8A) mode accordingly.

Check whether the smoke exhaust cowl is unobstructed.

Fill the water tank with water when needed.

Water filling

Check whether the safety valve/drain valve is closed.

Turn on the power supply of the water pump (main brake or pump switch). Open the hot water tap in the kitchen or bathroom and keep the valve open until the air in the container is bled and the water continuously discharged.

Without water heater heating, if only the cold water system is running, the water heater will be filled with water. To avoid frost damage, the water heater must be drained through a safety/drain valve, even if it is not in operation.

In case of frost, frozen residual water can prevent filling. The water heater only needs to be turned on for a while to defrost (no more than 2 minutes). The frozen part can be thawed after heating the inside of the water heater.



If the heater is connected to a central water supply system (rural or urban), a pressure reducer must be used to prevent the pressure from exceeding 2.8bar(0.28MPa).

- Turn on the circulating water pump.
- Turn on the hot water tap in the kitchen and bathroom until the air is bled to fill up the water tank and the water outlet will not be interrupted.

Turning off the Heater

After the heater is turned off, the combustion supporting fan and the heating fan will continue to work for several minutes according to the temperature of the furnace body. This is known as the cool down cycle and is to prevent radiating heat from damaging the heater.

In case of freezing hazard, the water tank must be emptied.

- Turn off the circulating water pump.
- Turn on the hot water taps in the kitchen and bathroom.

Drainage of the Heater

If the motor home is not used during a possibility of frost the Heater should be drained of water.

- Turn off the power supply of the pump unit (main power supply or pump switch).
- Turn on the hot tap in the kitchen and bathroom.
- To check the outflow of water, place a suitable container under the drain tank of the safety/drain valve (installation by users; used to



manually drain the water tank. The anti-freezing valve cannot ensure that the water tank is completely emptied).

- Turn on the safety/drain valve.
- The water in the Heater will be directly discharged to the outside through the safety/drain valve. Check whether all water in the heater has been drained into the container through the safety/drain valve. No claim for damages caused by frost is allowed during the warranty period.
- Use a 10L bucket to collect water for inspection to ensure that the water tank is empty.

Maintenance/Repair/Cleaning

- The device can only be repaired and cleaned by professionals.
- Maintenance, repair and cleaning cannot be done by children.
- Flush all hot/cold water hoses thoroughly before using the new equipment or after the equipment has not been used for a period of time.



Fault Information

During operation the Heater, the Heater may fail to start normally or shut down automatically after starting, and be in a fault locking state. At this time, the Heater can be turned off for more than 5 seconds and turned on again.

The Heater may cause circuit faults due to the following reasons:

- corrosion of connectors
- poor contact
- wrong insertion
- corrosion of wires or fuses
- corrosion of pile heads of storage batteries, etc.

During use, pay attention to inspection, maintenance, and prevention of these phenomena.

Users can handle and eliminate the following situations by themselves:

- After start up, the Heater does not start and the LCD Switch screen is not bright, which is due to open fuse or Wrong wiring; In addition, check whether the plug on the LCD switch lead is properly connected with the main machine.

Faults generated by the Heater will be displayed by the fault code on the LCD switch. Faults can be checked and eliminated using the table below.

Fault Codes

Code	Description	Troubleshooting Method
10	High voltage	Check Vehicle Supply
11	Low voltage	A) Check vehicle supply B) Check all connections and look for any damage in the wiring loom
21	Air outlet open circuit	Check whether the sensor is in good condition
22	Air outlet short circuit	Check whether the sensor is in good condition
23	Water temperature sensor open circuit	Check whether the sensor is in good condition
24	Water temperature sensor short circuit	Check whether the sensor is in good condition
25	External temperature sensor short circuit	Check whether the sensor is in good condition
26	External temperature sensor open circuit	Check whether the sensor is in good condition
27	Combustion temperature sensor open circuit	Check whether the sensor is in good condition
28	Combustion temperature sensor short circuit	Check whether the sensor is in good condition
31	Ignition failure	A) Check the fuel supply (air, dirty, or lack thereof) B) Check all inlets for blockages C) Check glow pin and flame sensor
32	Combustion Failure	A) Check the fuel supply (air, dirty, or lack thereof) B) Check all inlets for blockages C) Check the flame sensor
33	Flame Sensor Failure	A) Check the flame sensor leads B) Check the flame sensor
41	Hot air outlet temperature is too high	Check whether the air inlets and outlets are blocked
42	Hot air overheat switch protection	A) Check whether the air outlet is blocked B) Check the heater overheat switch
43	Water temperature is too high	A) Check whether the water tank is short of water B) Check whether the sensor is in good condition C) Check whether the water tank is short of water D) Check whether the sensor is in good condition
44	Water temperature overheat switch protection	A) Check whether the air outlet is blocked B) Check the water temperature overheat switch
45	Continuous overheat fault	A) Check whether the air outlet is blocked B) Check the water temperature sensor C) Check heater sensor
51	Communication failure	Check the connection cable



61	Fuel pump open circuit	A) Check whether the oil pump lead is damaged B) Check whether the oil pump lead connection is reliable C) Replace oil pump D) Replace ECU
62	Fuel pump short circuit	A) Check whether the oil pump lead is damaged B) Check whether the oil pump lead connection is reliable C) Replace oil pump D) Replace ECU
63	Glow pin open circuit	A) Check power supply voltage B) Check the normal temperature resistance of the glow pin (0.2Ω/12V) C) Clean up carbon deposits on glow pin D) Replace ECU
65	Glow pin has no drive	Replace ECU
81	Combustion air fan open circuit	Check combustion air fan
82	Combustion air fan failure to start	A) Check motor lead connection B) Check combustion air fan
83	Combustion air fan speed too low	Check combustion air fan
84	Air motor open circuit	Check air motor
85	Air motor failure to start	A) Check air motor lead B) Check air motor
86	Air motor speed is too low	Check air motor
110	Window opening alarm	Check window switch connection cable
120	Low voltage alarm	Recommend charging
220	220V no connection	Check AC 220V power supply system



Notes

.....

.....

.....

.....

.....

.....

.....

.....

.....

.....

.....

.....

.....

.....

.....

.....

.....

.....

.....

.....

.....

.....

.....